

# Solar Storage Inverter

## User Manual



### Product Model

DWA-8KLP1-EU

DWA-10KLP1-EU

# content

<b>1. Safety</b> .....	<b>1</b>
1.1、 How to use this manual .....	1
1.2、 Symbols in this manual .....	1
1.3、 Safety instruction .....	1
<b>2. Production Instructions</b> .....	<b>2</b>
2.1、 Instructions .....	2
2.2、 Features .....	2
2.3、 System connection diagram .....	3
2.4、 Production overview .....	4
<b>3. Installation</b> .....	<b>5</b>
3.1 Installation location .....	5
3.2 Inverter installation .....	6
3.3 Removal of terminal cover and insect-proof net .....	6
3.4、 Parallel wiring .....	7
3.4.1 Parallel operation .....	7
3.4.2 Cautions for parallel connection .....	7
<b>1.PV wiring:</b> .....	<b>7</b>
<b>2.Battery wiring</b> .....	<b>7</b>
<b>3.AC OUT wiring:</b> .....	<b>7</b>
<b>4.AC IN wiring:</b> .....	<b>7</b>
<b>5.Communication wiring:</b> .....	<b>8</b>
3.4.4 Three-phase parallel connection guide diagram .....	11
NOTE: .....	14
<b>4. Connection</b> .....	<b>15</b>
4.1 Single-Phase Output .....	15
4.2 Cable and circuit breaker model .....	17
● AC INPUT .....	17
4.3 AC input and output wiring .....	18
4.4、 Battery Connection .....	18
4.5 PV Connection .....	19
4.6 Dry contact wiring .....	19
4.7 Grounding Connection .....	20
4.8 Final assembly .....	20
4.9 Inverter start .....	20





<b>5. Operation</b> .....	<b>21</b>
5.1 Operation and display panel .....	21
● View real-time data .....	24
5.2、 Setting .....	25
5.3、 AC output mode .....	31
5.4、 Battery charging mode .....	32
• Hybrid Charging SNU (default) .....	32
5.5 Timed charge/discharge function .....	33
5.6 Battery parameters .....	34
• <b>Lead-acid battery</b> .....	<b>34</b>
<b>6.Communication</b> .....	<b>36</b>
6.1、 Overview .....	36
6.2、 USB-B Port .....	36
6.4、 CAN/RS485-2 Port .....	37
6.5、 Dry contact .....	38
<b>7. Fault and Remedy</b> .....	<b>39</b>
7.1、 Fault Code .....	39
7.2、 Troubleshooting .....	43
<b>8. Protection and Maintenance</b> .....	<b>45</b>
8.1、 Protection features .....	45
8.2、 Maintenance .....	46
<b>9. Datasheet</b> .....	<b>47</b>

# 1. Safety

## 1.1. How to use this manual

- This manual contains important information, guidelines, operation and maintenance for the following products: DWA-8KLP1-EU, DWA-10KLP1-EU
- The manual must be followed during installation, using and maintenance.

## 1.2. Symbols in this manual

Symbol	Description
	DANGER indicates a hazardous situations which if not avoided will result in death or serious injury.
	WARNING indicates a hazardous situations which if not avoided could result in death or serious injury.
	CAUTION indicates a hazardous situations which if not avoided could result in minor or moderate injury.
	NOTICE provides some tips on operation of products.

## 1.3. Safety instruction

### DANGER

- This chapter contains important safety instructions. Read and keep this manual for future reference.
- Be sure to comply the local requirements and regulation to install this inverter.
- Beware of high voltage. Please turn off the switch of each power sources before and during the installation to avoid electric shock.
- For optimum operation of this inverter, please follow required specification to select appropriate cable size and necessary protective device.
- Do not connect or disconnect any connections when the inverter is working.
- Do not open the terminal cover when the inverter working.
- Make sure the inverter is well grounding.
- Never cause AC output and DC input short circuited.
- Do not disassembly this unit, for all repair and maintenance, please take it to the professional service center.
- Never charge a frozen battery.

## 2. Production Instructions

### 2.1、 Instructions

DW series is a new type of solar energy storage inverter control inverter integrating solar energy storage & utility charging and energy storage, AC sine wave output. It adopts DSP control and features high response speed, reliability, and industrial standard through an advanced control algorithm.

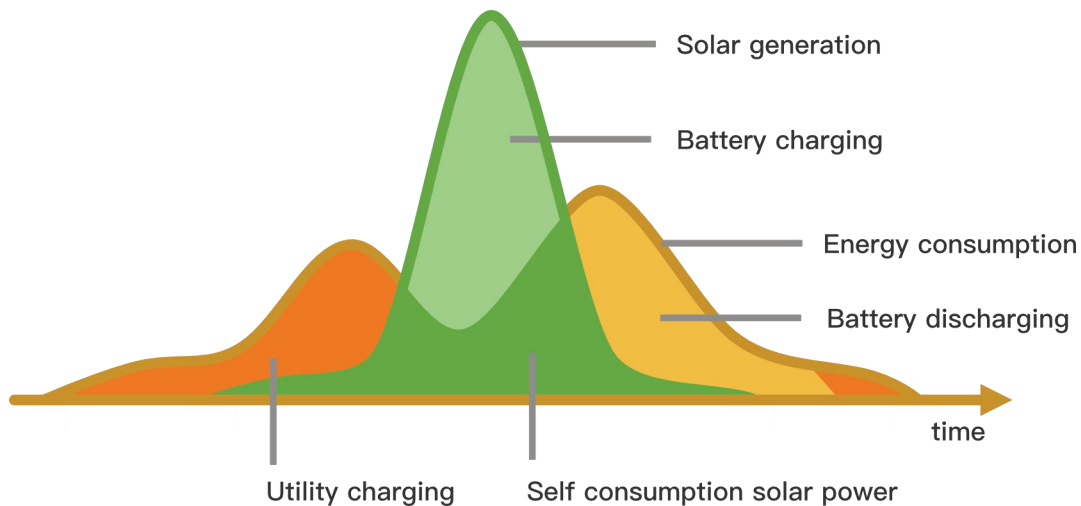

### 2.2、 Features

- Supports lead acid battery and li-ion battery connections.
- With a dual activation function when the li-ion battery is dormant; either mains or photovoltaic power supply access can trigger the activation of the li-ion battery.
- Supports single-phase parallel and parallel three-phase pure sine wave output.
- Stand-alone or parallel systems support 200, 208, 220, 230 and 240Vac voltage levels
- Supports two solar inputs and simultaneous tracking of two solar maximum power charging/carrying capacity functions.
- Dual MPPT with 99.9% efficiency and maximum 22A current in a single circuit, perfectly adapted to high power modules.
- 4 charging modes are available: solar only, mains priority, solar priority, and mixed mains and PV charging.
- Time-slot charging and discharging setting function is available in both off-grid and hybrid grid-connected modes.
- Stand-alone energy saving mode function to reduce no-load energy losses.
- With two output modes of utility bypass and inverter output, with uninterrupted power supply function.
- LCD large screen dynamic flow diagram design, easy to understand the system data and operation status.
- 360° protection with complete short circuit protection, over current protection, over under voltage protection, overload protection, etc.
- Support CAN, USB, and RS485 communication.
- With N grounding option.

## 2.3、 System connection diagram

The diagram below shows the system application scenario of this product. A complete system consists of the following components:

**1.PV modules:** converts light energy into DC energy, which can be used to charge the battery via an inverter or directly inverted into AC power to supply the load.

**2.Utility grid or generator:** connected to the AC input, it can supply the load and charge the battery at the same time. The system can also operate generally without the mains or generator when the battery and the PV module power the load.

**3.Battery:** The role of the battery is to ensure the regular power supply of the system load when the solar energy is insufficient and there is no mains power.

**4.Home load:** Various household and office loads can be connected, including refrigerators, lamps, televisions, fans, air conditioners, and other AC loads.

**5.Inverter:** The energy conversion device of the whole system.

The actual application scenario determines the specific system wiring method.

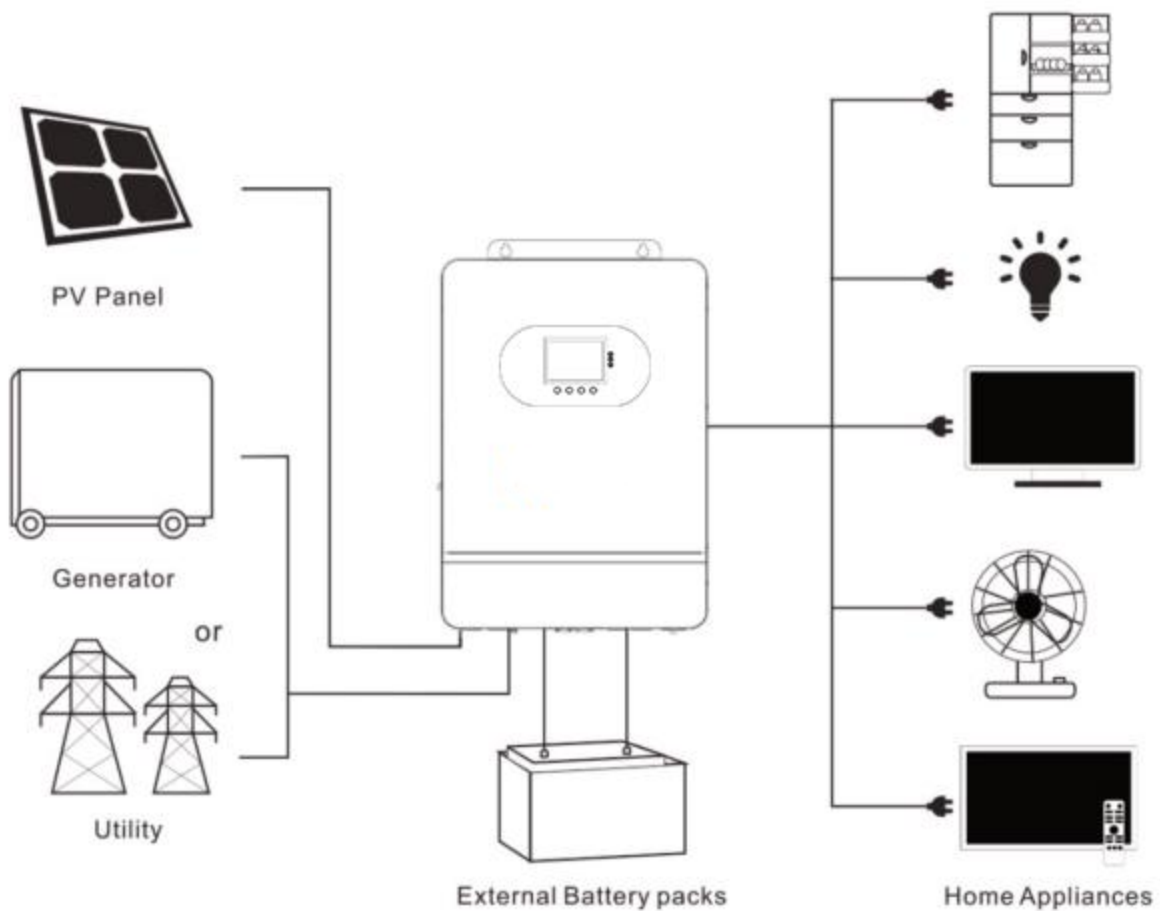

## 2.4、 Production overview

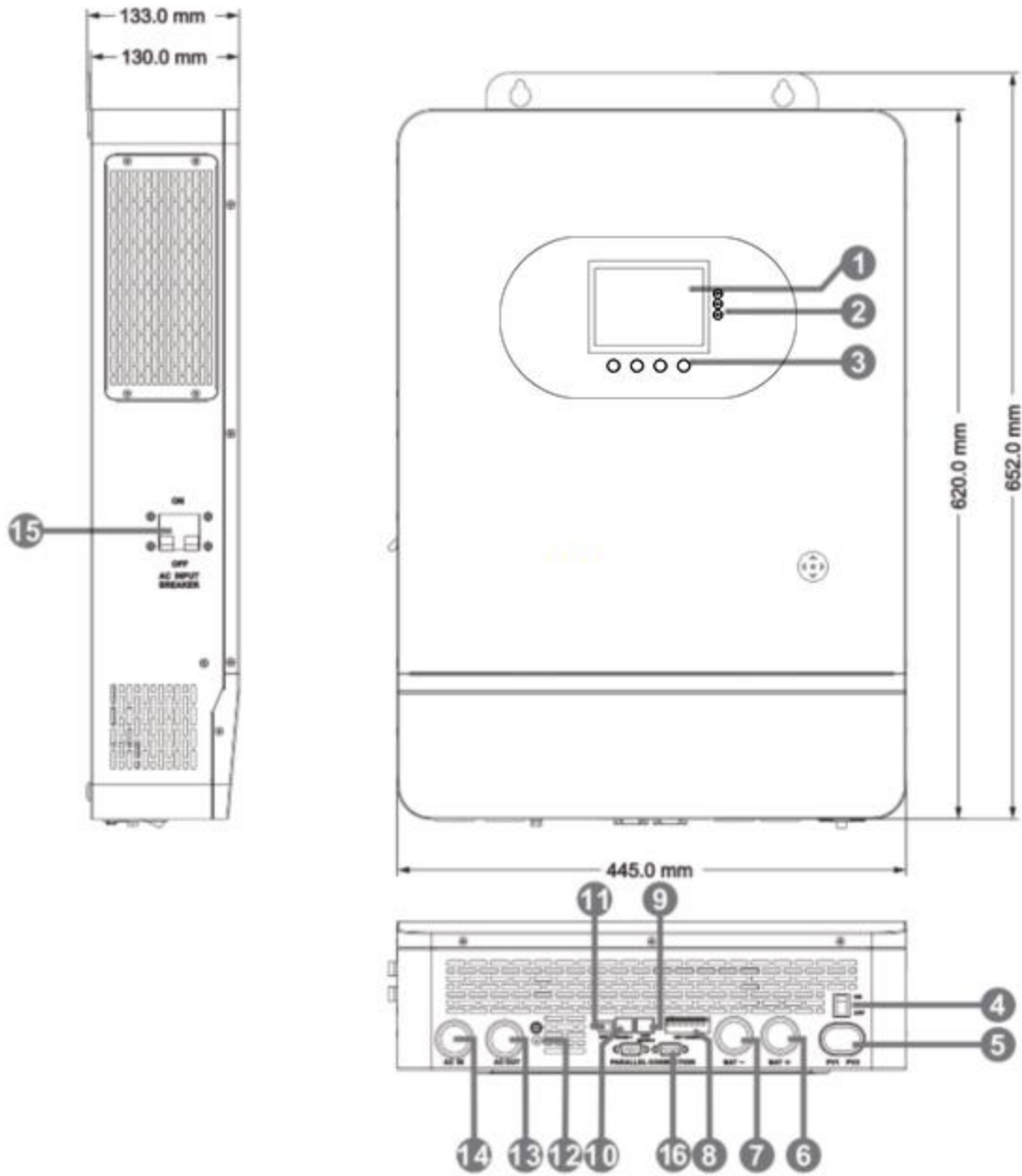

1	LCD screen	2	LED indicator	3	Physical button
4	ON/OFF rocker switch	5	PV input (1/1)	6	Battery (+)
7	Battery (-)	8	Dry contact	9	CAN/RS485-2 port
10	RS48-1 port	11	USB-B port	12	Grounding screw
13	AC output (L+N)	14	AC input (L+N)	15	AC input circuit breaker
16	Parallel communication port				

## 3. Installation

### 3.1 Installation location

DW series is only for indoor use (**protection level: IP20**). Before selecting the installation location, users should consider the following factors:

- A solid wall
- Installation height: flush with the line of sight
- Sufficient heat dissipation space
- Ambient temperature:  $-10^{\circ}\text{C}$ – $55^{\circ}\text{C}$  ( $14^{\circ}\text{F}$ – $131^{\circ}\text{F}$ ), to ensure optimal operation

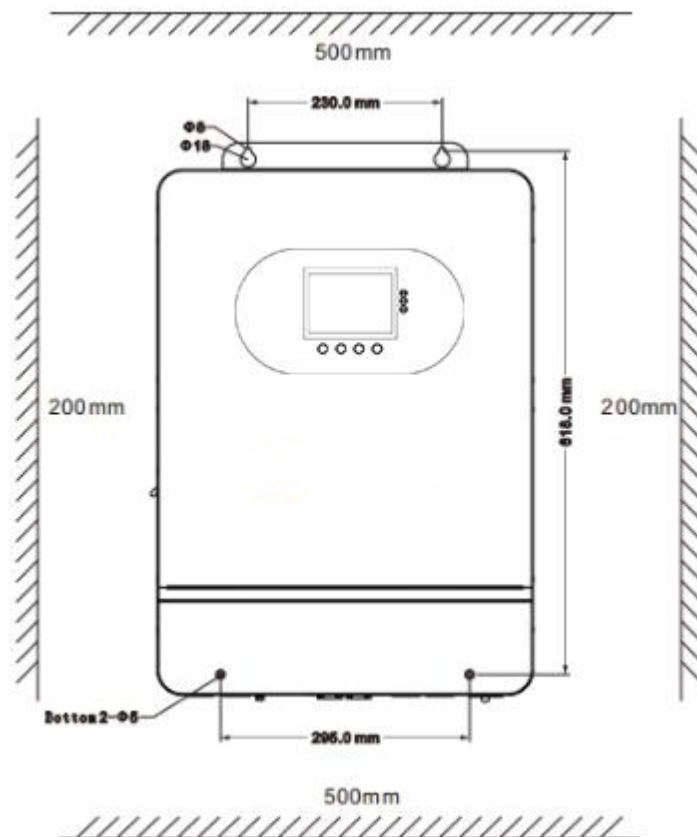

#### DANGER

- Do not install the inverter near highly flammable materials
- Do not install the inverter in potentially explosive areas
- Do not install the inverter and lead-acid battery in enclosed spaces

#### CAUTION

- Do not install the inverter in direct sunlight
- Do not install or use the inverter in damp environments

### 3.2 Inverter installation

Make 4 mounting holes in the wall with a drill according to the specified dimensions, insert two expansion screws above and two M5 size screws below for fixing the inverter.

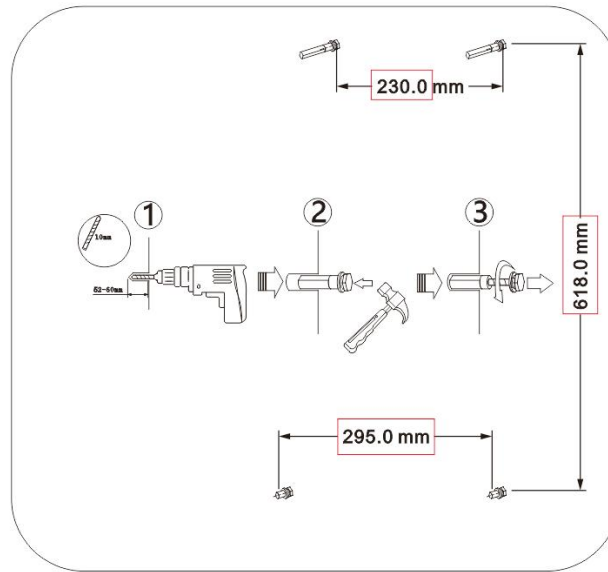

### 3.3 Removal of terminal cover and insect-proof net

Remove the terminal cover and insect-proof net with a screwdriver

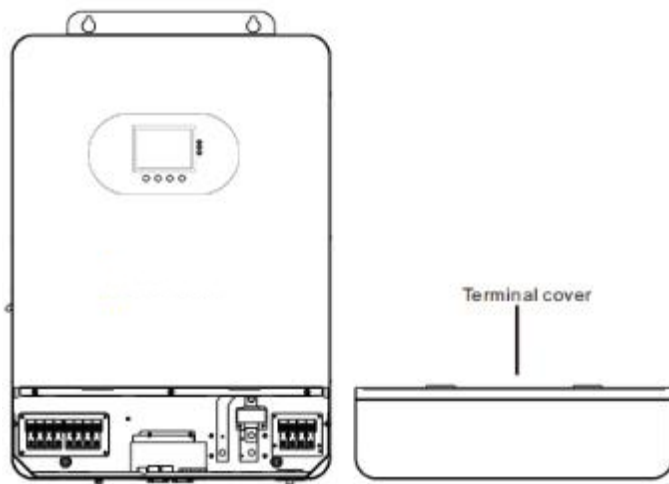

Remove the insect-proof net when cleaning

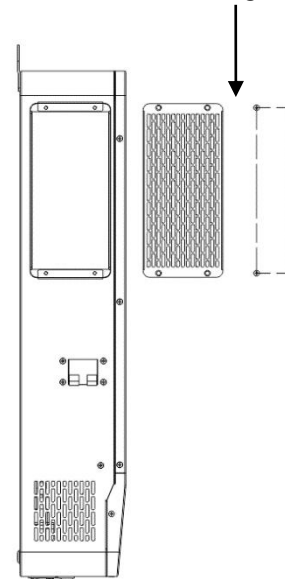

#### ⚠ NOTICE

- When using the inverter in areas with poor air quality, the dustproof net is easily blocked by air particles. Please regularly remove and clean it to avoid affecting the air flow rate inside the inverter; otherwise it may cause inverter overheating (19/20 fault), and affect power supply and the service life of the inverter

## 3.4、 Parallel wiring

### 3.4.1 Parallel operation

1. The parallel operation supports up to six solar storage inverters.
2. When using the parallel function, it is necessary to connect the parallel communication cable in a correct and reliable manner. See the figure blow for the communication cable (packaging accessory):

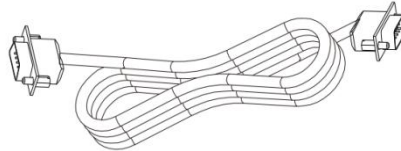

### 3.4.2 Cautions for parallel connection

#### Warning:

##### 1.PV wiring:

In parallel connection, the PV array of each inverter must be independent, and the PV array of PV1 and PV2 for one inverter must also be independent.

##### 2.Battery wiring

In single-phase or three-phase parallel connection, all solar storage inverters must be connected to the same battery, with BAT+ connected to BAT+ and BAT- to BAT-, and before power on and start-up, it is necessary to check and ensure correct connection, wiring length, and cable size, so as to avoid the abnormal operation of parallel system output caused by wrong connection.

##### 3.AC OUT wiring:

In single-phase parallel connection, all solar storage inverters must be connected in the manner of L-to-L, N-to-N, and PE-to-PE, and before power on and start-up, it is necessary to check and ensure correct connection, wiring length, and cable size, so as to avoid the abnormal operation of parallel system output caused by wrong connection.

In three-phase parallel connection, all solar storage inverters must be connected in the manner of N-to-N and PE-to-PE. The L lines of all inverters in the same phase shall be connected together, but the AC output L lines of different phases shall not be connected together. Other cautions are the same as those for single-phase parallel connection.

##### 4.AC IN wiring:

In single-phase parallel connection, all solar storage inverters must be connected in the manner of L-to-L, N-to-N, and PE-to-PE, and before power on and start-up, it is necessary to check and ensure correct connection, wiring length, and cable size, so as to avoid the abnormal operation of parallel system output caused by wrong connection. Meanwhile, it is not allowed to have multiple different AC source inputs to avoid damage to the external equipment of the inverter. The AC source input shall be consistent and unique.

In three-phase parallel connection, all solar storage inverters must be connected in the manner of N-to-N and PE-to-PE. The L lines of all inverters in the same phase shall be connected together, but the AC

output L lines of different phases shall not be connected together. Other cautions are the same as those for single-phase parallel connection.

**5.Communication wiring:**

Our company's communication cable for parallel operation is a DB15 standard computer cable with shielding function, and it is used for single-phase or three-phase parallel connection. Each inverter shall be connected with one out and one in, that is, the male connector (out) of the inverter is to be connected to the female connector (in) of the parallel inverter, not the one of the inverter. In addition, DB15 terminal screws will be used to tighten the communication cable of each parallel inverter to avoid falling off or poor contact of the communication cable, followed by abnormal operation or damage of the system output.

6.Before and after connecting the system, please carefully refer to the following system wiring diagrams to ensure that all wiring is correct and reliable before power on.

7.After the system is correctly wired, powered on, and in normal operation, if a new inverter needs to be connected, make sure to disconnect the battery input, PV input, AC input and AC output, and that all solar storage inverters are powered off before reconnecting into the system.

**3.4.3 Single-phase parallel connection guide diagram**

1. Parallel communication line and even flow detection line of inverse control unit need to be connected after screw locking. The schematic diagram is as follows:

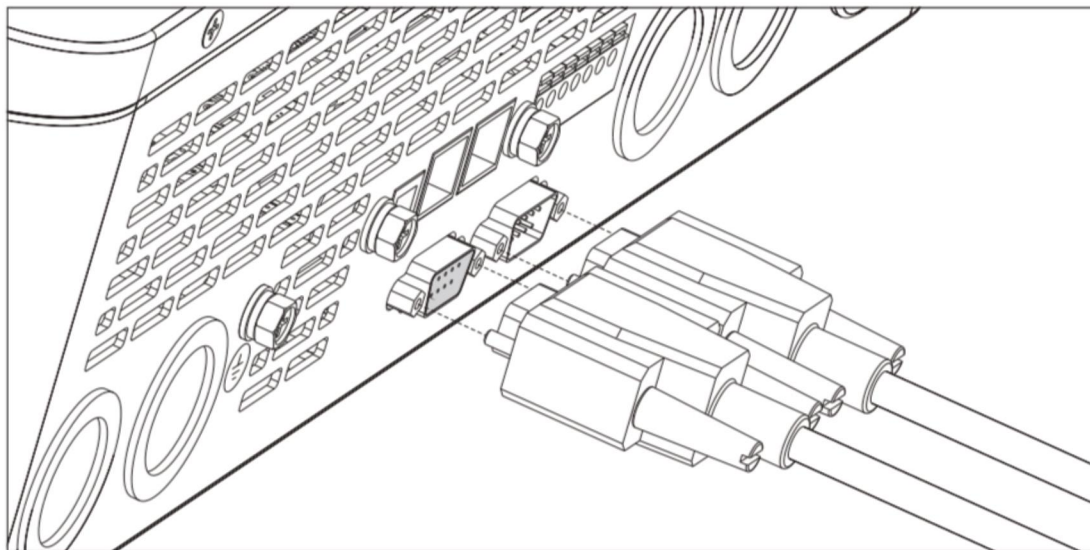

2、 When multiple machines are connected in parallel, the parallel connection diagrams are as follows:

**a. Two all-in-one solar charger inverters of the system connected in parallel**

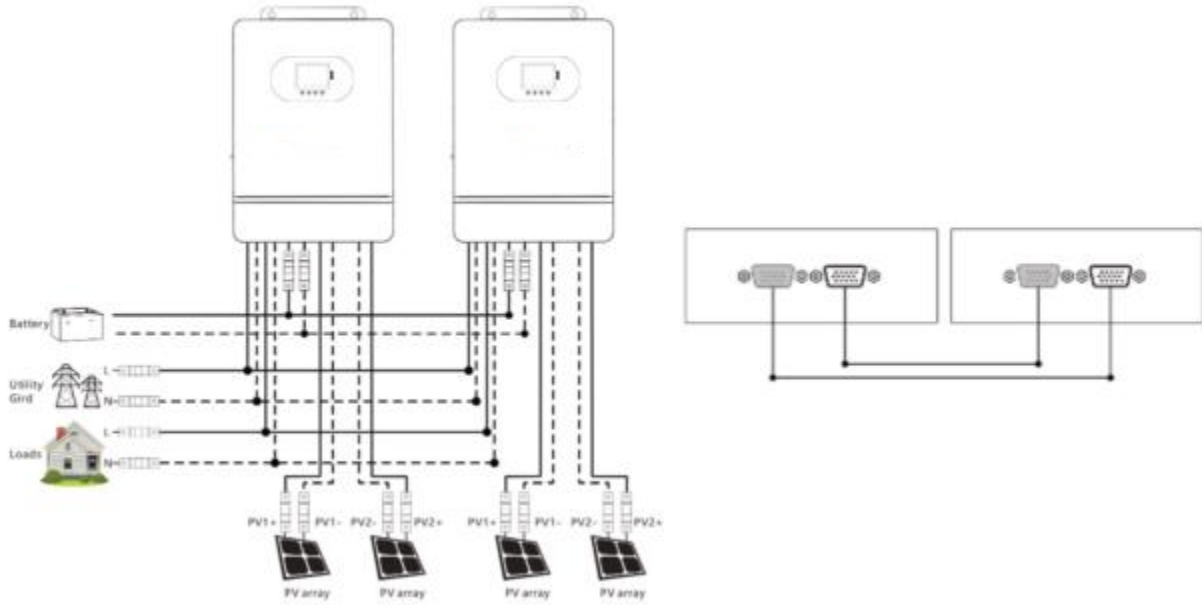

**b. Three all-in-one solar charger inverters of the system connected in parallel**

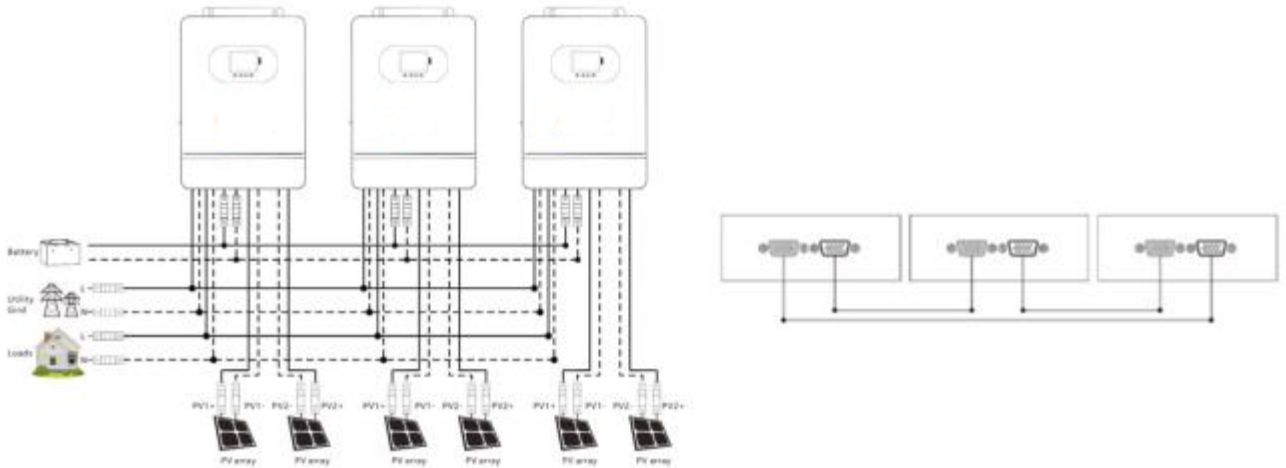

**c. Four all-in-one solar charger inverters of the system connected in parallel**

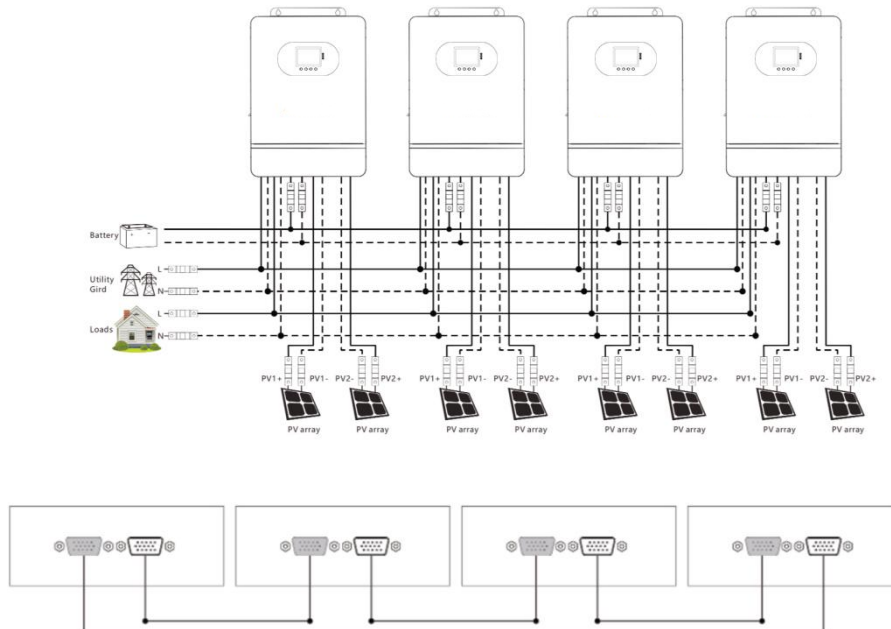

**d. Five all-in-one solar charger inverters of the system connected in parallel**

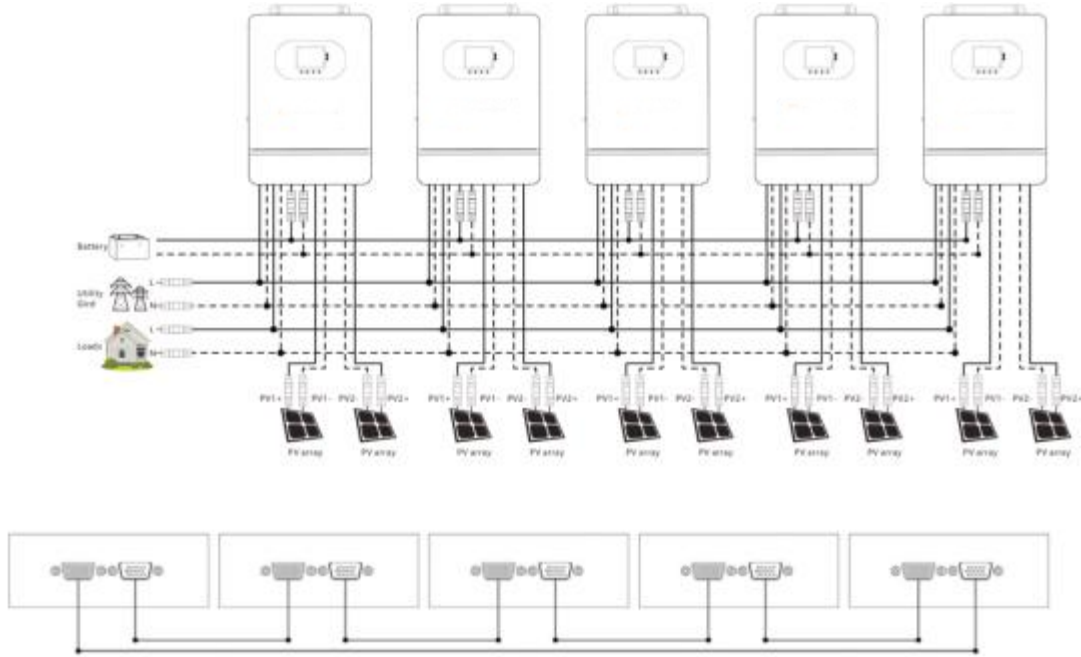

**e. Six all-in-one solar charger inverters of the system connected in parallel**

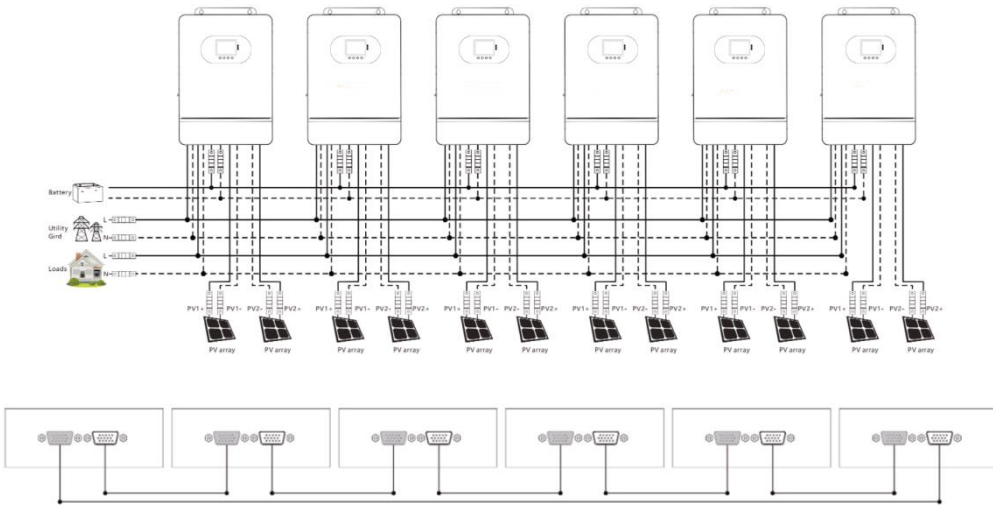

### 3.4.4 Three-phase parallel connection guide diagram

1.Parallel communication line of the inverters needs to be connected and then screwed and locked. The schematic diagram is as follows:

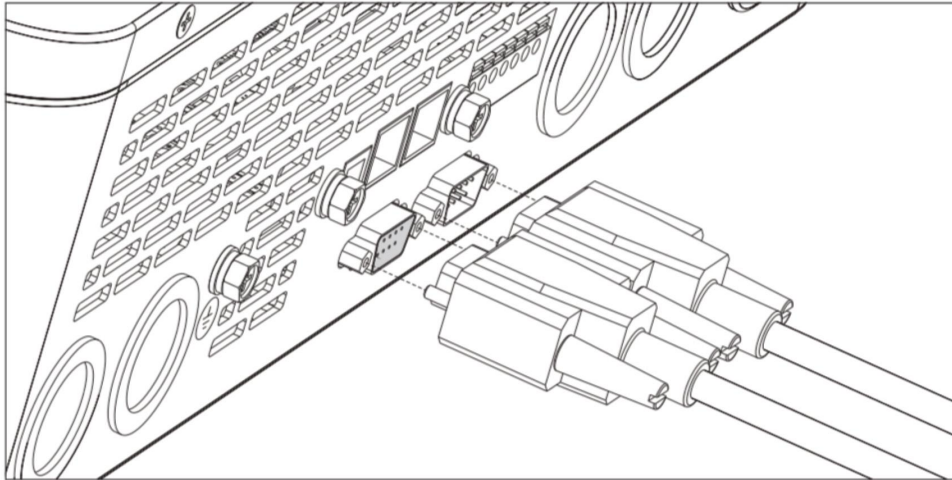

Three-phase parallel

**a. Three all-in-one solar charger inverters of the system connected in three phase**

1+1+1 System

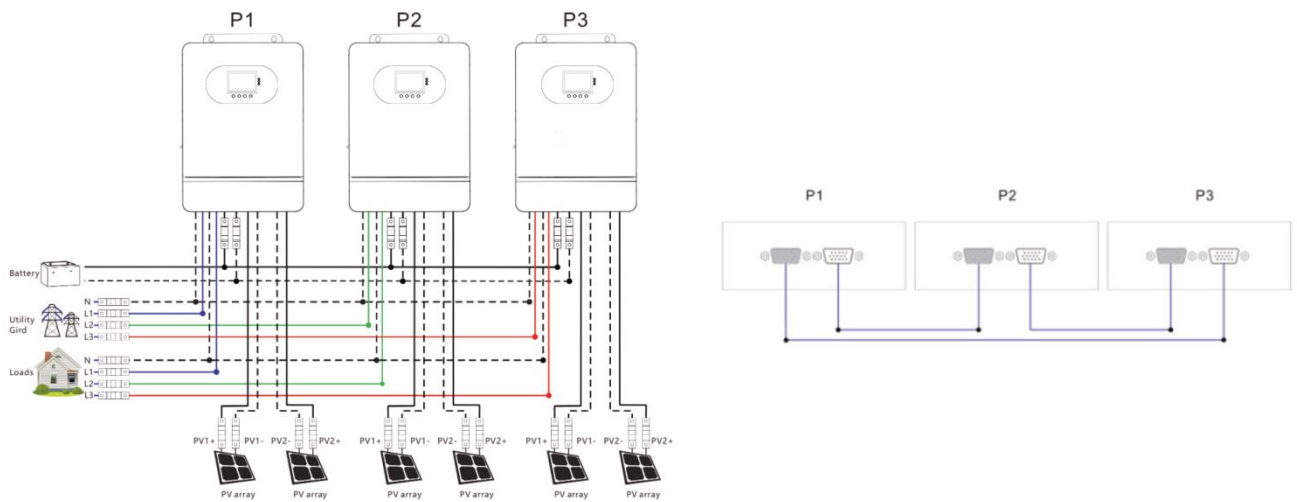

**b. Four all-in-one solar charger inverters of the system connected in three phase**

2+1+1 System

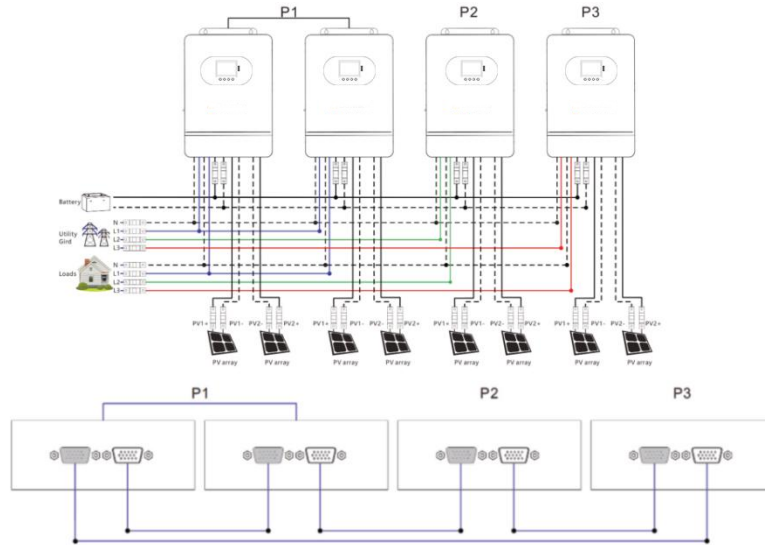

**c. Five all-in-one solar charger inverters of the system connected in three phase**

2+1+1 System

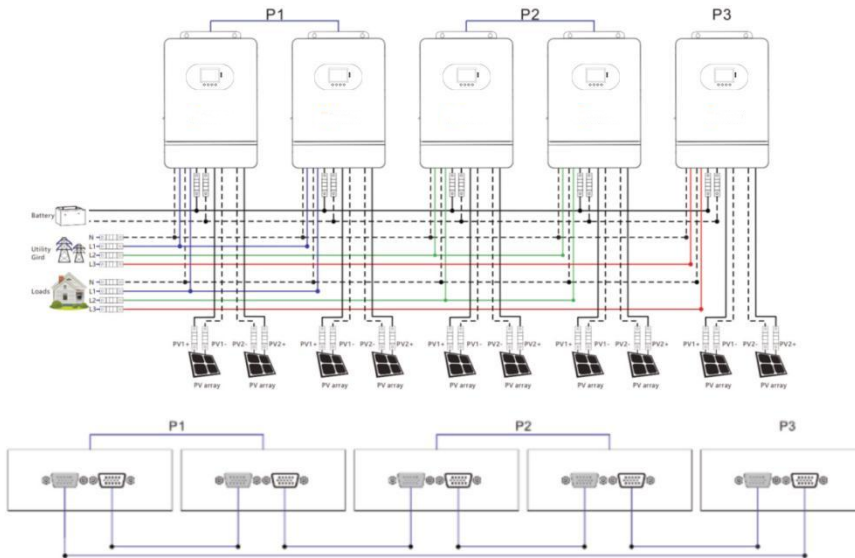

3+1+1 System

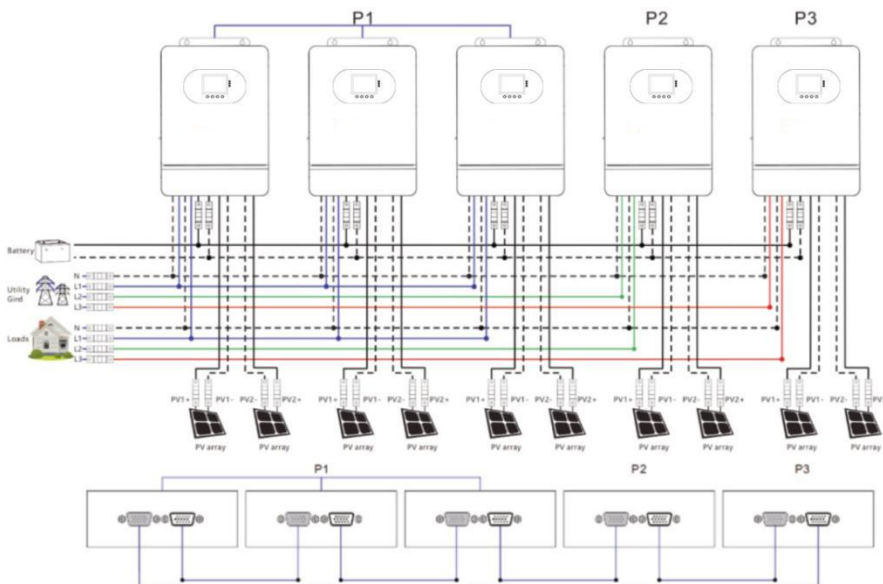

**d. Six all-in-one solar charger inverters of the system connected in three phase**

2+2+2 system:

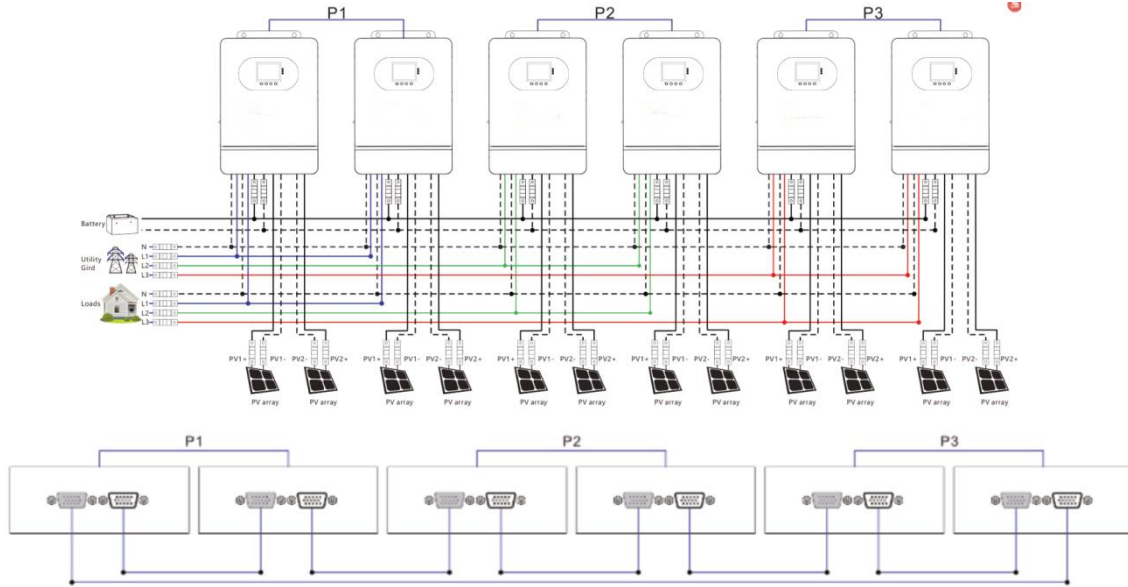

3+2+1 System

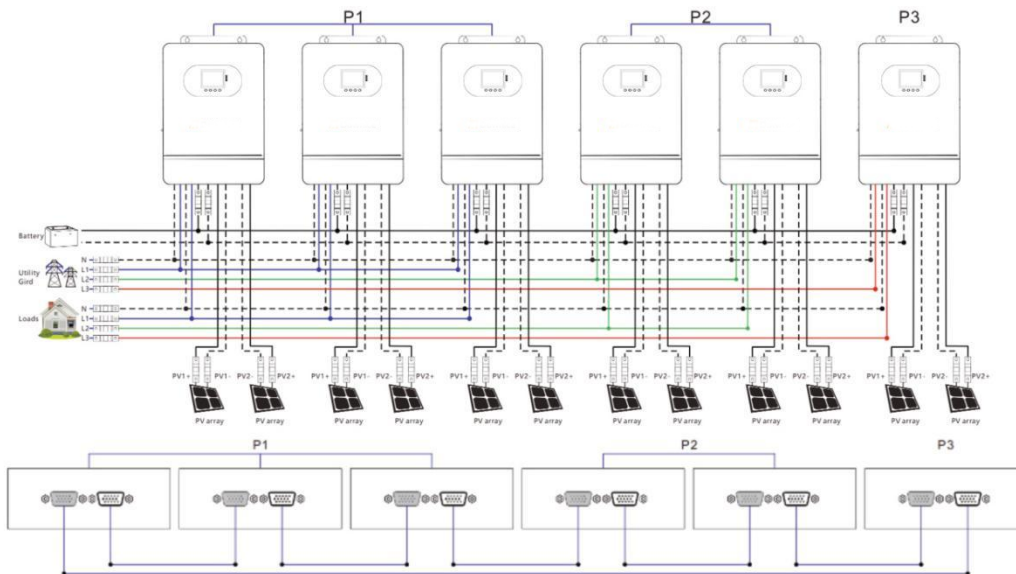

4+1+1 System

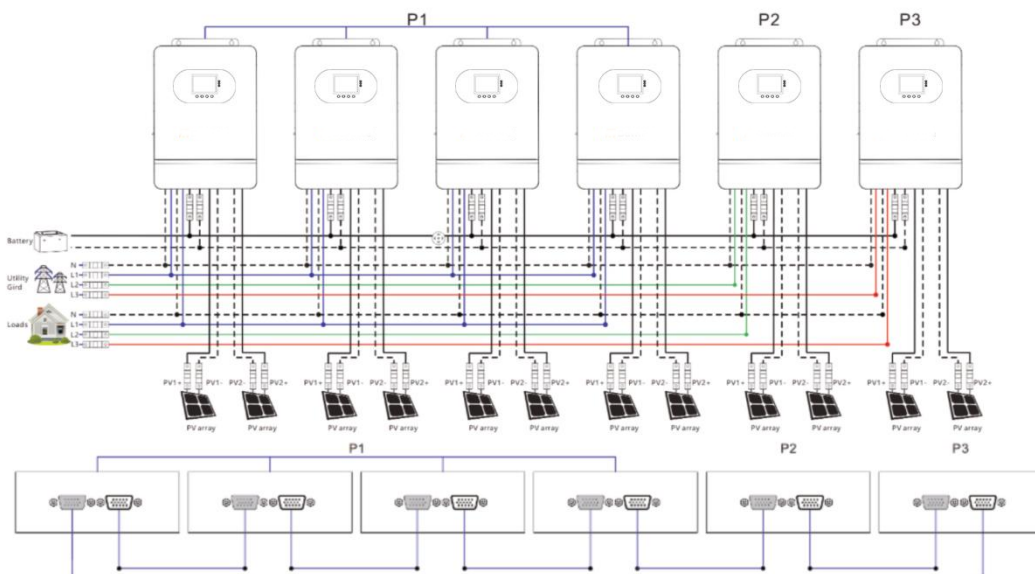

**NOTE:**

1. Before starting up and running, please check whether the connection was correct to avoid any abnormalities in the system.
2. All wiring must be fixed and reliable to avoid wire drop during use.
3. When the AC output is wired to the load, it shall be properly wired according to the requirements of the electrical load equipment to avoid damage to the load equipment.
4. Settings [38] need to be set consistently or only for the host. When the machine is running, the voltage set by the host shall prevail, and the master will force the rewrite of the other slave machines to keep the same set. Only can be set in the standby mode.
5. Machine factory default for single machine mode, if you use parallel or three-phase function, you need to set the [31] item parameters through the screen. The setting method is: power on one machine at a time, the rest of the machine off, and then set the [31] item parameters according to the site system operation mode. After this machine is set successfully, turn off the machine switch and wait for the machine to be powered down, then set the rest of the machines in turn until all machines are set, and then all machines are powered up again at the same time and enter the working state.

The [31] setting item:

When in single phase parallel connection : setting 【31】 should be set as 【PAL】 .

When in three phase parallel connection, all machines in phase 1 must be set as 【3P1】 , all machines in phase 2 must be set as 【3P2】 all machines in phase 3 must be set as 【3P3】 , at present, the voltage phase difference between P1-P2, P1-P3 and P2-P3 is 120 degrees.

a. When the output voltage set in the setting 【38】 is 230Vac, the line voltage between fire wire L1 in phase 1 and fire wire L2 in phase 2 is  $230 \times 1.732 = 398\text{Vac}$ , and similarly the line voltage between L1-L3, L2-L3 is 398Vac.

6. After the system runs, the output voltage is measured correctly, and then the load setting is connected.

## 4. Connection

### 4.1 Single-Phase Output

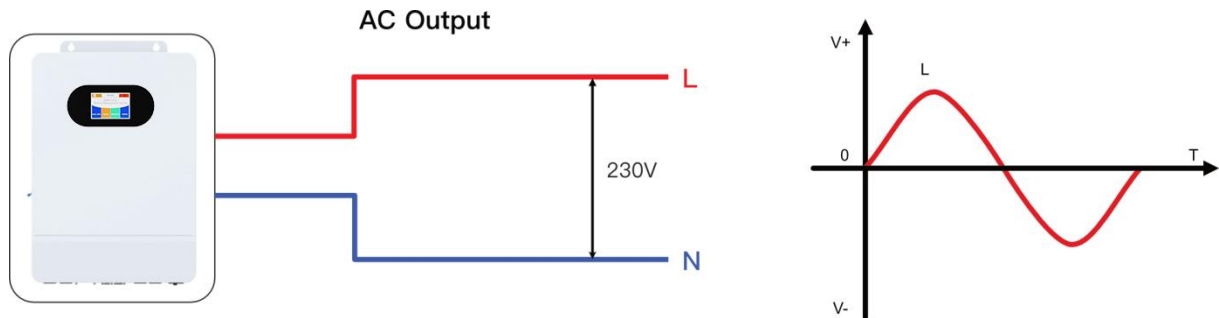

Item	Description
Applicable model	DWA-8KLP1-EU/DWA-10KLP1-EU
AC output voltage Range(L-N)	200 ~ 240Vac, 230Vac default

#### ⓘ NOTICE

- Users can change the output voltage by setup menu. Please read the chapter 5.2 Setting.
- Output voltage corresponds parameter 38 , the output voltage can be set from 200V to 240V.

# Single-phase Mode

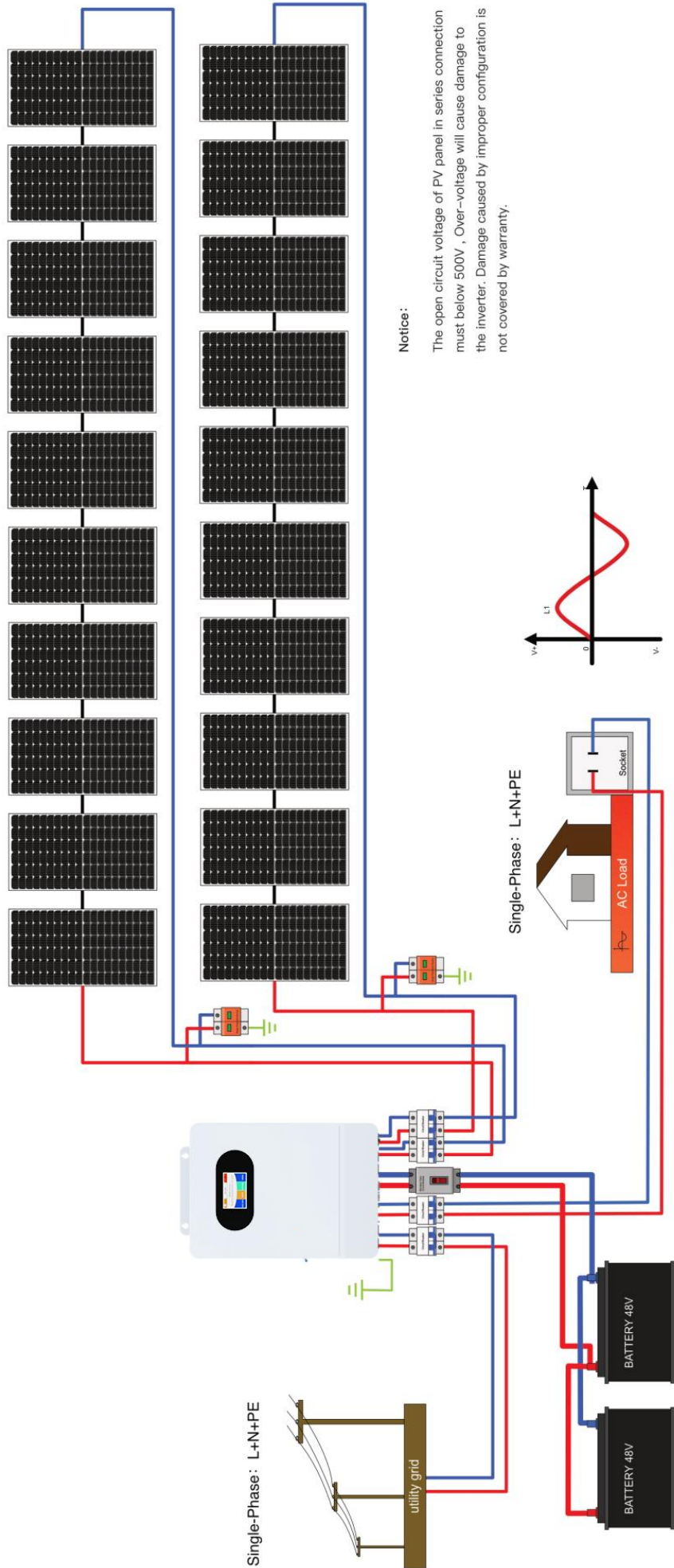

**Notice:**

The open circuit voltage of PV panel in series connection must be below 500V , Over-voltage will cause damage to the inverter. Damage caused by improper configuration is not covered by warranty.

Single-Phase: L+N+PE

Single-Phase: L+N+PE

## 4.2 Cable and circuit breaker model

### ● PV INPUT

Inverter Model	Cable Size	Maximum Input Current	Circuit Breaker Model
DWA-8KLP1-EU	5 mm <sup>2</sup> /10 AWG	22 A	2P-25A
DWA-10KLP1-EU	5 mm <sup>2</sup> /10 AWG	22 A	2P-25A

### ● AC INPUT

Inverter Model	Output Mode	Maximum Current	Cable Size	Circuit Breaker Model
DWA-8KLP1-EU	Single-phase	63A (L/N)	13mm <sup>2</sup> /6 AWG (L/N)	2P-63A
DWA-10KLP1-EU	Single-phase	63A (L/N)	13mm <sup>2</sup> /6 AWG (L/N)	2P-63A

### ● Battery

Inverter Model	Cable Size	Maximum Current	Circuit Breaker Model
DWA-8KLP1-EU	34 mm <sup>2</sup> /2 AWG	180 A	2P-200A
DWA-10KLP1-EU	42 mm <sup>2</sup> /1 AWG	220 A	2P-250A

### ● AC output

Inverter Model	Output Mode	Maximum Current	Cable Size	Circuit Breaker Model
DWA-8KLP1-EU	Single-phase	63A (L/N)	13mm <sup>2</sup> /6 AWG (L/N)	2P-63A
DWA-10KLP1-EU	Single-phase	63A (L/N)	13mm <sup>2</sup> /6 AWG (L/N)	2P-63A

#### ⓘ NOTICE

##### PV input, AC input, and AC output terminals

1. Use a wire stripper to strip off 6 mm – 8 mm long insulation layer of the cable.
2. Fix a sleeve at the end of the cable (the sleeve is to be prepared by the user)

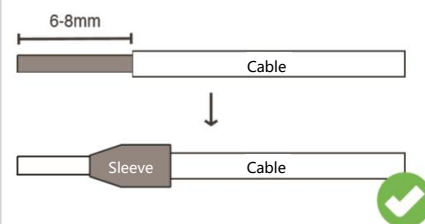

##### Battery terminal

1. Use a wire stripper to strip off 6 mm – 8 mm long insulation layer of the cable.
2. Fix a ring terminal (attached) at the end of the cable

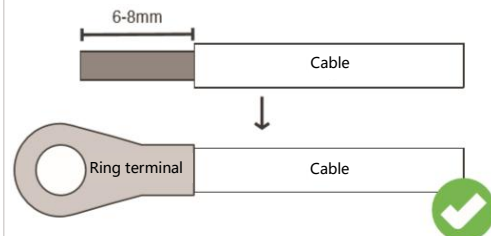

The wire diameter is for reference only. If the distance between the PV array and the inverter or between the inverter and the battery is long, using a thicker wire will reduce the voltage drop and improve the performance of the system.

### 4.3 AC input and output wiring

Connect the fire wire, zero wire and ground wire according to the cables' position and order shown in the diagram below.

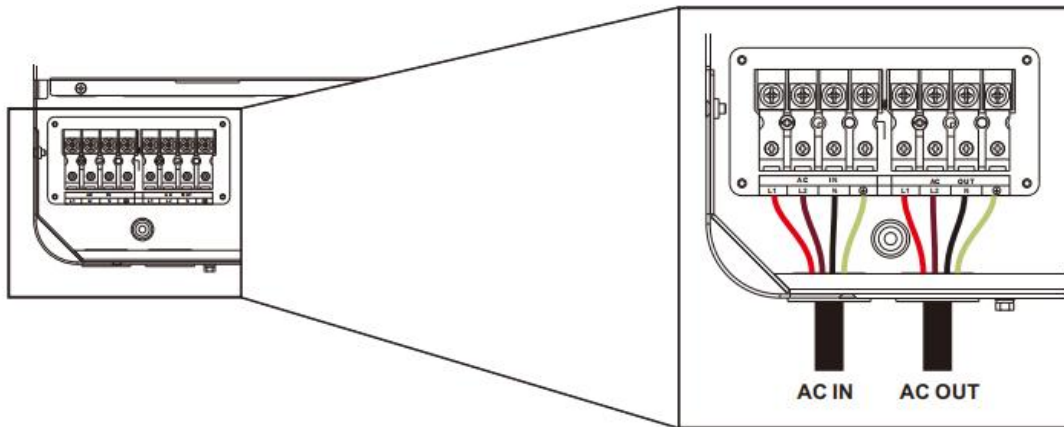

**⚠ DANGER**

- Before connecting AC input and output, be sure to disconnect the circuit breaker to avoid the risk of electric shock. Do not conduct live operation.
- Please check whether the cables used are sufficient to meet the requirements. Cables that are too thin or of poor quality may pose serious safety hazards.

### 4.4. Battery Connection

Connect the positive and negative cable of the battery according to the diagram below.

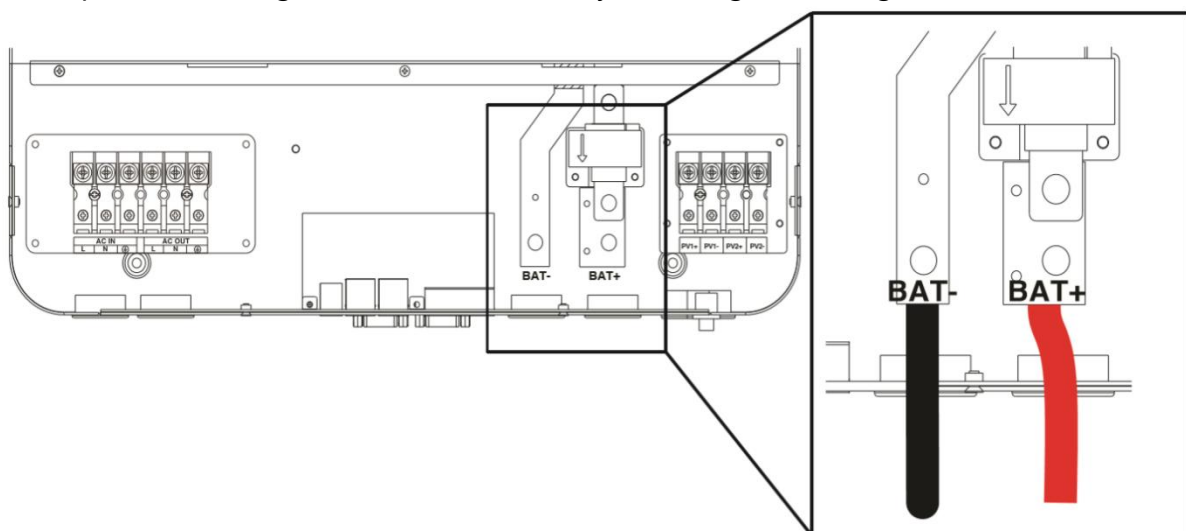

**⚠ DANGER**

- Before connecting the battery, be sure to disconnect the circuit breaker to avoid the risk of electric shock. Do not conduct live operation.
- Please check the positive and negative terminals of the battery for correct connection and no reverse connection; otherwise it may damage the inverter.
- Please check whether the cables used are sufficient to meet the requirements. Cables that are too thin or of poor quality may pose serious safety hazards.

## 4.5 PV Connection

Connect the positive and negative wires of the two strings of PV according to the diagram below.

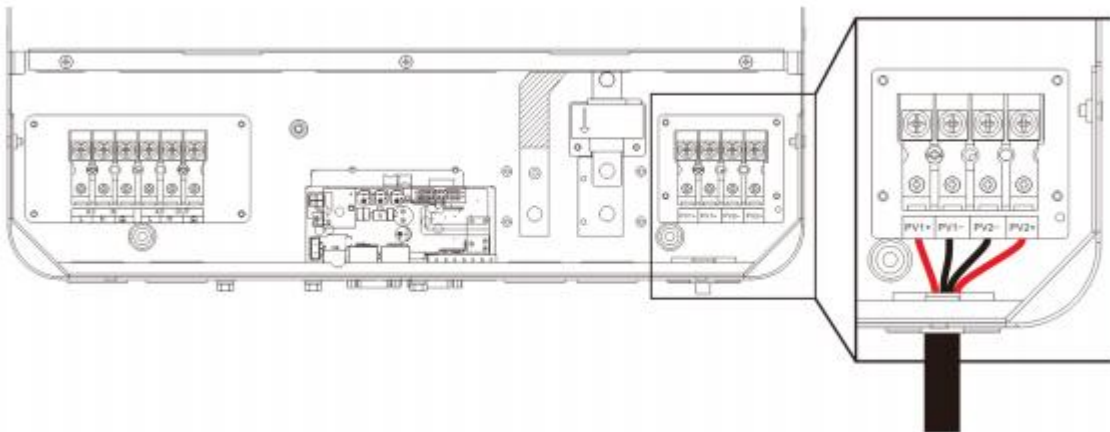

### **DANGER**

- Before connecting PV modules, be sure to disconnect the circuit breaker to avoid the risk of electric shock. Do not conduct live operation.
- Please make sure that the open circuit voltage of the series connected PV modules does not exceed the maximum open circuit voltage of the inverter (in DW series, this value is 500 V); otherwise the inverter may be damaged.

## 4.6 Dry contact wiring

Use a small-sized screwdriver to push back in the direction indicated by the arrow, and then insert the communication cable into the dry contact port. (Communication cable section: 0.2 mm<sup>2</sup>–1.5 mm<sup>2</sup>)

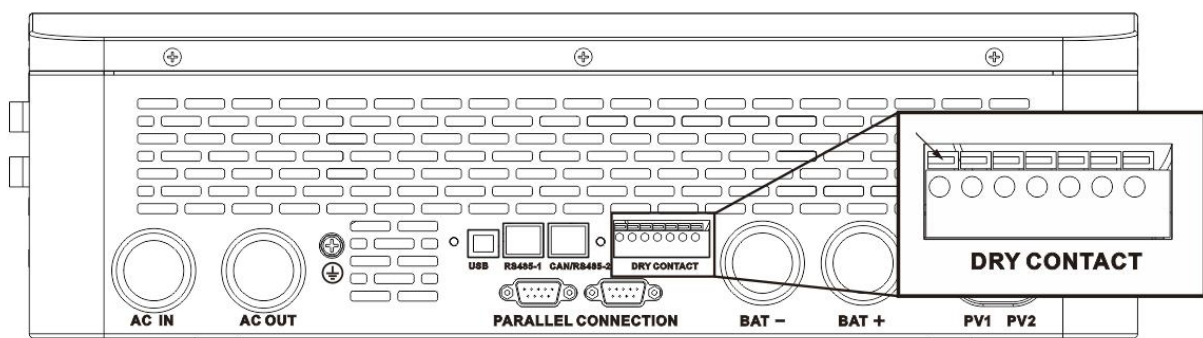

## 4.7 Grounding Connection

Please ensure that the grounding terminal is reliably connected to the grounding busbar.

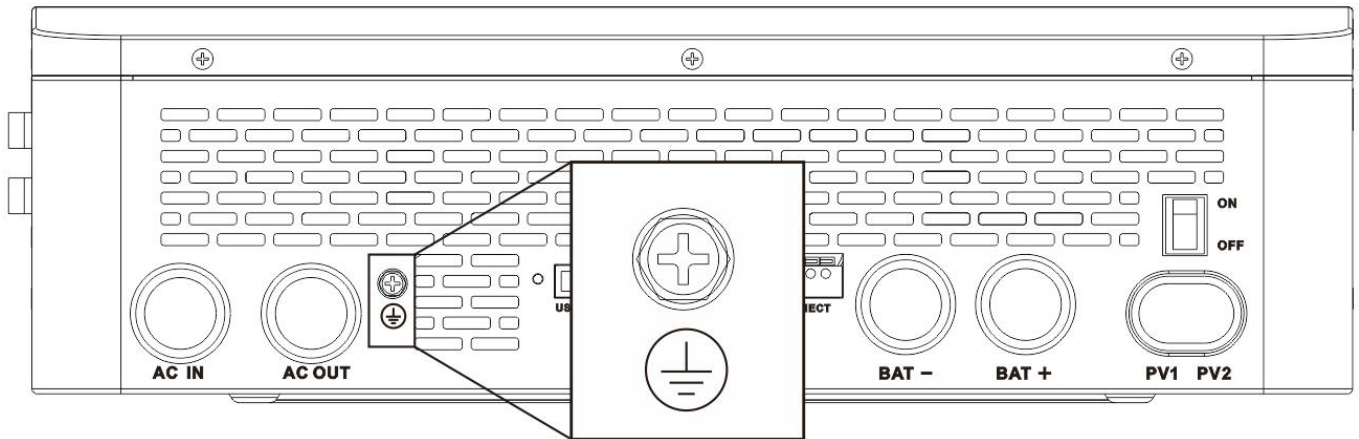

### NOTICE

- The grounding cable should have a diameter of not less than 4 mm<sup>2</sup> and be as close as possible to the grounding point.

## 4.8 Final assembly

After ensuring that the wiring is reliable and the wire sequence is correct, install the terminal protection cover in place.

## 4.9 Inverter start

After confirming reliable wiring and correct wiring sequence, restore the terminal cover to its original position

- Step 1: Close the circuit breaker of the battery
- Step 2: Press the rocker switch at the bottom of the inverter, and the screen and indicator will light up, indicating that the inverter is enabled
- Step 3: Close the circuit breakers for PV input, AC input, and AC output in sequence
- Step 4: Start loads one by one in order of power from small to large



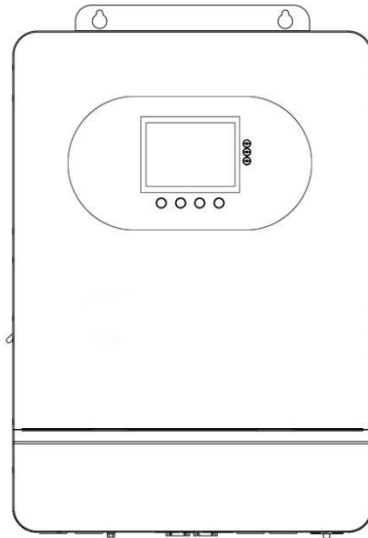

## 5. Operation

### 5.1 Operation and display panel

The operation and display panel of the inverter includes one LCD screen, three indicators, and four physical buttons



#### ● Physical button

Physical button	Description
	Enter/Exit the setup menu
	Go to the next option
	Go to the previous option
	Confirm/Enter the option in setup menu



#### ● LED indicator

Indicator	Color	Description
AC/INV	Yellow	Normally ON: mains bypass output
		Flash: inverter output
CHARGE	Green	Normally ON: charging completed
		Flash: charging
FAULT	Red	Normally ON: level-1 fault
		Flash: level-2 fault
		OFF: level-3 or level-4 fault

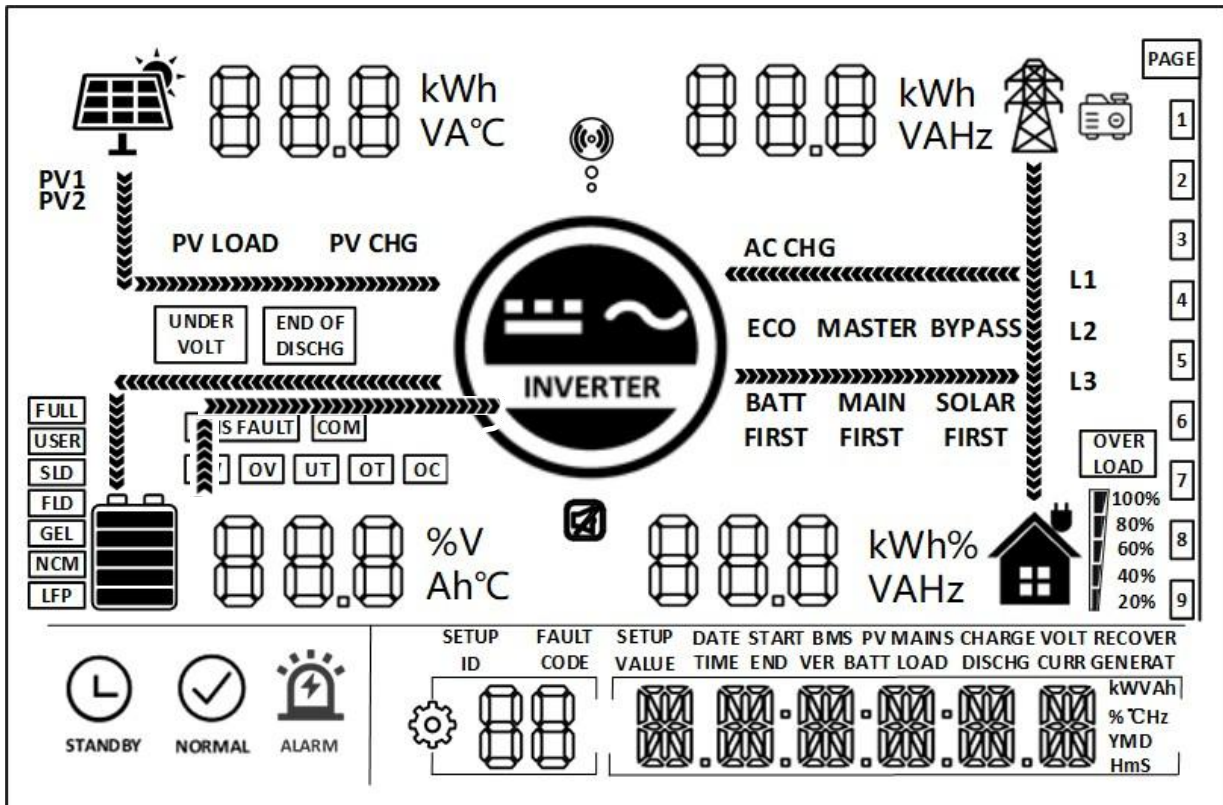
● Display screen



Icon	Description	Icon	Description
	PV panel		Grid
	Battery		Generator
	The inverter is working		Load
	The inverter is communicating with the data collector		The buzzer is in mute mode
	Power flow direction		
	The inverter is in standby mode		The inverter is working normally
	There is a fault		Settings
	Load power: 80%–100%		SOC: 80%–100%
	Load power: 60%–79%		SOC: 60%–79%
	Load power: 40%–59%		SOC: 40%–59%
	Load power: 20%–39%		SOC: 20%–39%

Icon	Description	Icon	Description
	Load power: 5%–19%		SOC: 5%–19%
<b>UNDER VOLT</b>	Battery under-voltage	<b>END OF DISCHG</b>	Battery over-discharge
<b>OVER LOAD</b>	Overload	<b>BMS FAULT</b>	BMS fault
<b>COM</b>	System communication error	<b>UV</b>	System under-voltage
<b>OV</b>	System over voltage	<b>UT</b>	Too low system temperature
<b>OT</b>	Too high system temperature	<b>OC</b>	System over current
<b>FULL</b>	Battery full power	<b>USER</b>	User-defined battery
<b>SLD</b>	Sealed lead-acid battery	<b>FLD</b>	Flooded lead-acid battery
<b>GEL</b>	Gel lead-acid battery	<b>NCM</b>	Ternary Li-ion battery
<b>LFP</b>	LFP Li-ion battery	<b>ECO</b>	Energy-saving mode
<b>PVLOAD</b>	PV power is loading	<b>PVCHG</b>	PV power is charging the battery
<b>ACCHG</b>	AC input power is charging the battery	<b>MAINS FIRST</b>	The output mode of the inverter is mains first
<b>BYPASS</b>	The output mode of the inverter is mains bypass	<b>SOLAR FIRST</b>	The output mode of the inverter is PV first
<b>BATT FIRST</b>	The output mode of the inverter is battery first		

## ● View real-time data

In the main screen, press the UP / DOWN keys to view the real-time data of the inverter during operation.

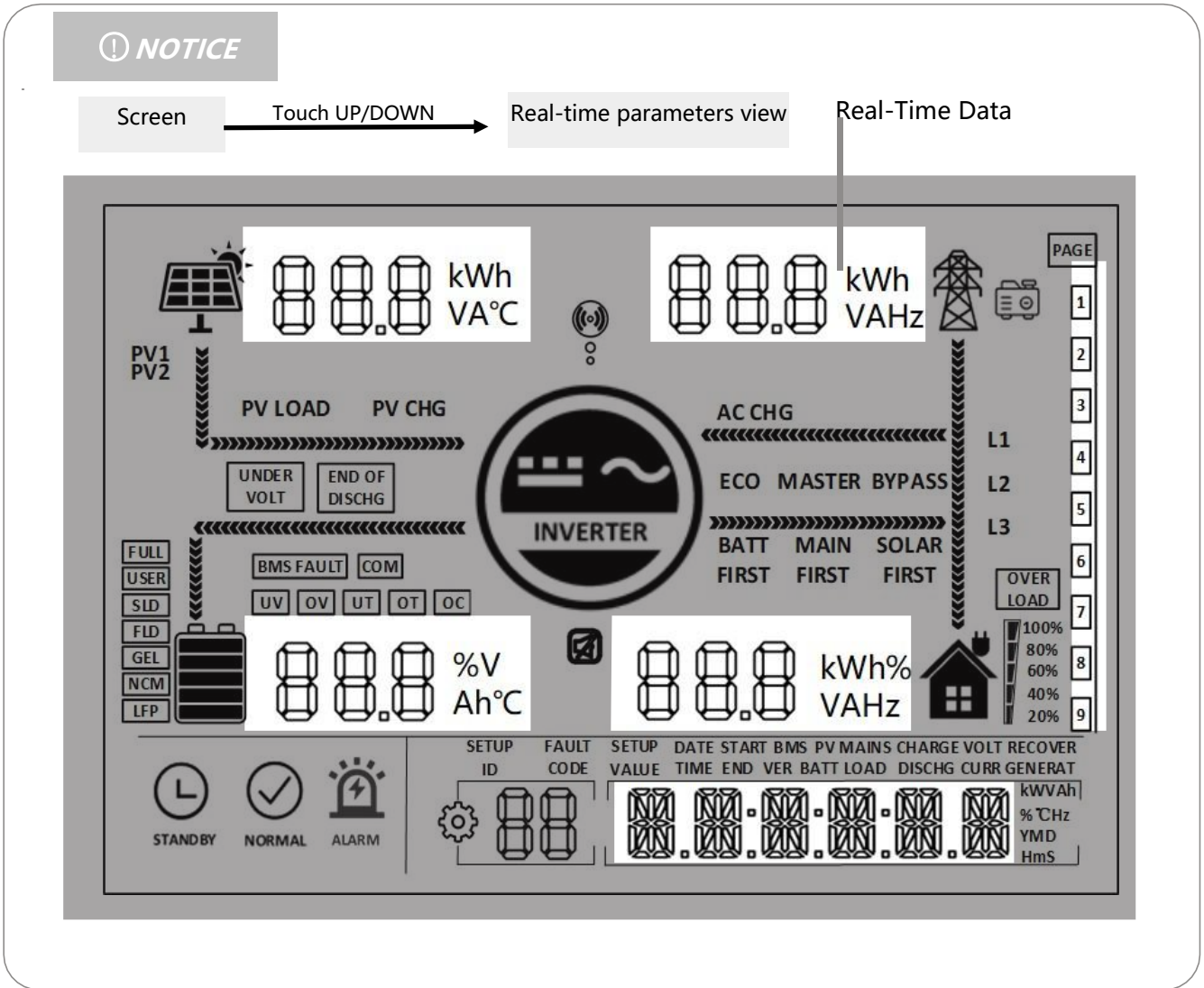

Page	PV	Battery	AC input	Load	General
1	PV input voltage	Battery voltage	Mains input voltage	Single-phase voltage	Current time
2	PV input current	Battery current	Mains input current	Single-phase current	Current date
3	PV input power	Battery voltage	Mains total input power	Single-phase active power	PV gross generation
4	PV generation for the day	Battery current	Mains charging capacity for the day	Single-phase apparent power	Total load consumption
5	PV heat sink temperature	Heat sink temperature	Mains frequency	Inverter output frequency	RS485 address
6	Rated open circuit voltage	Rated battery voltage	Bus voltage	Rated output frequency	Software version
7	Maximum PV charge current	Maximum battery charge current	Maximum mains charge current	Total output active power	/
8	/	/	/	Total output apparent frequency	/

## 5.2、Setting

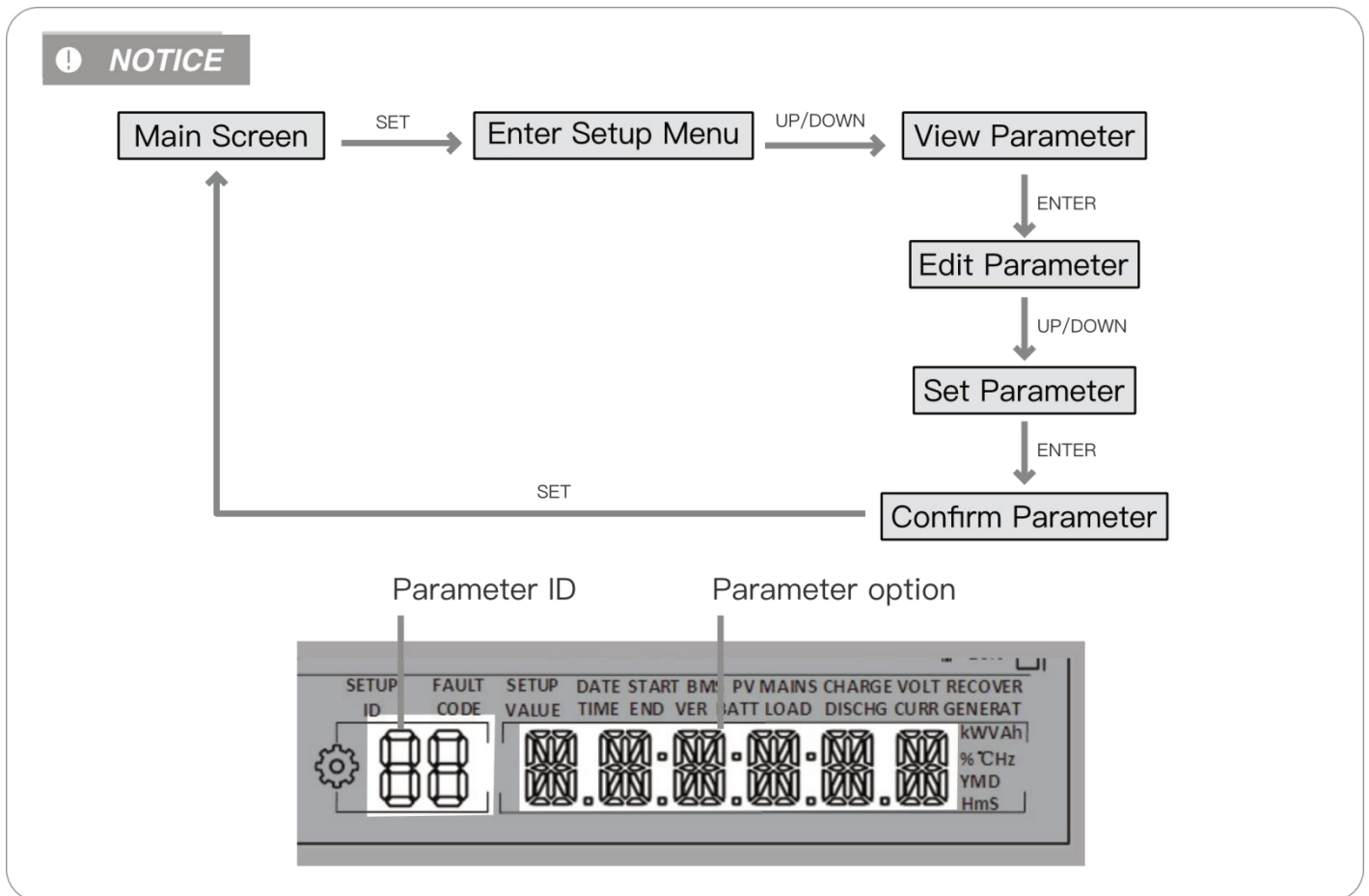

ID	Parameter	Option	Description
The voltage setting logic: 【15】 < 【12】 < 【04】 < 【14】 < 【35】 < 【37】 < 【05】 < 【09/11】			
00	Exit	ESC	Exit the setup menu
01	AC output mode	UTI (default)	Photovoltaic energy priority with the load, photovoltaic is not enough, the grid power and photovoltaic mixed load, photovoltaic energy is enough with the load, the excess energy to charge the battery, the grid power only starts charging when the battery is too discharged (06 Settings as "OSO(only PV) ", the grid power will not charge), the battery is only discharged when off the grid
		SBU	Inverter at first priority, utility will provide power to load when the battery voltage below parameter [04] value. When the battery voltage is higher than parameter [05] value or when it is full, switching from utility to inverter.
		SOL	Solar at first priority, utility will provide power to load when solar power is not available and the battery voltage below parameter [04] value.

ID	Parameter	Option	Description
		SUB	Solar energy priority charging, insufficient solar energy, grid energy and solar energy hybrid charging (if 06 Settings as "OSO(only PV) ", the grid energy will not charge) and grid with load, when solar energy is enough to charge, excess energy not enough to load, excess solar energy and grid will hybrid load, the battery is discharged only when off the grid
02	AC input frequency	50.0	In bypass mode, the AC output frequency will adapt to the mains frequency, and in other cases, the output will follow the preset value.
		60.0 (default)	
03	AC input voltage range	UPS (default)	When output range is 220/230V, input voltage range 170~280V.
		APL	When output range is 220/230V, input voltage range 90~280V, frequency range changes to 40-70 Hz. Can only be set in off-grid mode. Hybrid mode (parameter [34]) automatically changes to ups.
04	Battery to mains voltage threshold	43.6 (default)	When parameter 01 = SBU/SOL, output source will switch to utility from battery when the battery voltage below the preset value. Setting range:40~52V.
05	Mains to battery voltage threshold	57.6 (default)	When parameter 01 = SBU/SOL, output source will switch to battery from utility when the battery voltage above the preset value. Setting range:48~60V.
06	Battery charge mode	SNU (default)	When both PV power and mains are used to charge the battery at one time, the PV charge first and when the PV power is insufficient, the mains tags in. Only in bypass mode can both PV power and mains be used to charge the battery at one time, and only the PV charge mode can be enabled during inverter operation.
		OSO	Do not enable the mains charge mode when in only PV charge mode
07	Battery charge current	60	DWA-8KLP1-EU, setting range: 0 A–180 A
			DWA-10KLP1-EU, setting range: 0 A–200 A
08	Battery type	USER	User-defined, and in this type, you can set all battery parameters
		SLD	Sealed lead-acid battery
		FLD	Flooded lead-acid battery
		GEL (default)	Gel lead-acid battery
		L14/L15/L16	LFP battery L14/L15/L16, corresponding to 14, 15, and 16 series of LFP batteries
		N13/N14	Ternary Li-ion battery N13/N14, corresponding to 13 and 14 series of ternary Li-ion batteries
		NOb	No battery

ID	Parameter	Option	Description
09	Battery boost charge voltage	57.6	Setting range: 48 V–58.4 V, with a step of 0.4 V, available for user-defined and lithium-ion battery types
10	Boost charge duration	120	The continuous charging time when the voltage reaches the set voltage during constant voltage charging, with a setting range of 5 min–900 min and a step of 5 min
11	Battery floating charge voltage	55.2	Setting range: 48 V–58.4 V, with a step of 0.4 V. This parameter cannot be set after successful BMS communication
12	Battery over-discharge voltage (delay off)	42	When the battery voltage is lower than the voltage and triggers the set value in the item 13, it will turn off the inverter output. Setting range: 40 V–48 V, with a step of 0.4 V
13	Battery over-discharge delay time	5	When the battery voltage is lower than the set value in the item 12 and triggers the delay time set in this parameter item, it will turn off the inverter output. Setting range: 5s–50s, with a step of 5s
14	Battery under-voltage alarm threshold	44	When the battery voltage is lower than the threshold, it will give an under-voltage alarm and the output will not shut down. Setting range: 40 V–52 V, with a step of 0.4 V
15	Battery discharge limit voltage	40	When the battery voltage is lower than the value, the output immediately shuts down. Setting range: 40 V–52 V, with a step of 0.4 V, available for user-defined and Li-ion batteries
16	Battery equalizing charge	DIS	Disable equalizing charge
		ENA (default)	Enable equalizing charge, but only available for flooded lead-acid batteries, sealed lead-acid batteries, and user-defined ones
17	Equalizing charge voltage	58	Setting range: 48 V–58 V, with a step of 0.4 V, but only available for flooded lead-acid batteries, sealed lead-acid batteries, and user-defined ones
18	Equalizing charge duration	120	Setting range: 5 min–900 min, with a step of 5 min, but only available for flooded lead-acid batteries, sealed lead-acid batteries, and user-defined ones
19	Equalizing charge delay time	120	Setting range: 5 min–900 min, with a step of 5 min, but only available for flooded lead-acid batteries, sealed lead-acid batteries, and user-defined ones
20	Equalizing charge interval	30	Setting range: 0 day–30 days, with a step of 1 day, but only available for flooded lead-acid batteries, sealed lead-acid batteries, and user-defined ones
21	Battery equalization charging stop-start	DIS (default)	Start equalizing charge immediately
		ENA	Stop equalizing charge immediately
22	Power saving mode (Supports stand-alone mode only)	DIS (default)	Disable energy-saving mode
		ENA	Enable energy-saving mode, and when the load power is below 50 W, it will turn off the inverter output after a 5-minute delay. When it exceeds 50 W, the inverter will automatically restart.

ID	Parameter	Option	Description
23	Overload auto restart	DIS	When overload occurs and the output is switched off, the machine will not restart.
		ENA (default)	When overload occurs and the output is switched off, the machine will restart after a delay of 3 mins. After it reaches 5 cumulative time, the machine will not restart automatically.
24	Over-temperature auto restart	DIS	Disable over-temperature auto restart and when over-temperature occurs, it will turn off the output and the inverter will no longer turn on the output
		ENA (default)	Enable over-temperature auto restart and when over-temperature occurs, it will turn off the output and the output will restart when the temperature drops
25	Buzzer alarm	DIS	Disable buzzer alarm
		ENA (default)	Enable buzzer alarm
26	Power source switching reminder	DIS	Disable reminder when the status of the input power source changes.
		ENA (default)	Enable reminder when the status of the input power source changes.
27	Inverter overload switch to bypass	DIS	Disable switch to the bypass automatically when the inverter is overload.
		ENA (default)	Enable switch to the bypass automatically when the inverter is overload.
28	Max. utility charging current	60 (default)	DWA-8KLP1-EU, setting range: 0 A–100 A
			DWA-10KLP1-EU, setting range: 0 A–120 A
30	RS485 address	ID: 1	Setting range: 1–254, Parallel mode: 1~6.
31	AC output mode (Settable only in standby mode)	SIG (default)	Single inverter operation
		PAL	Parallel operation
		3P1/3P2/3P3	Three-phase parallel operation
		All machines in phase 1 must be set as <b>【3P1】</b> , all machines in phase 2 must be set as <b>【3P2】</b> , all machines in phase 3 must be set as <b>【3P3】</b> . When the output voltage set in the setting <b>【38】</b> is 230Vac: At present, the voltage phase difference between P1-P2, P1-P3 and P2-P3 is 120 degrees. The line voltage between fire wire L1 in phase 1 and fire wire L2 in phase 2 is $230 \times 1.732 = 398\text{Vac}$ , and similarly the line voltage between L1-L3, L2-L3 is 398Vac. The line voltage between L1-N, L2-N, L3-N is 230Vac.	
32	RS485 communication function	SLA (default)	Enabling PC and remote monitoring protocols.
		485	Enabling BMS communication based on RS485.
		CAN	Enabling BMS communication based on CAN.
33	BMS communication	When item 32 is set to 485 or CAN, the corresponding communication protocol must be selected in item 33.	

ID	Parameter	Option	Description
			PAC=PACE, RDA=RITAR, AOG=ALLGRAND, OLT=OLITER, HWD=SUNWODA, DAQ=DYNESS, WOW=SRNE, PYL=PYLONTECH, UOL=VILION
34	On-grid and mixed load function	DIS (default)	Disable the function
		ONGRD	On-grid function, Solar is charged first and any surplus power after the load demand is met is fed back to the grid. (Item 01 is set to UTI, item 03 is set to UPS, item 06 is set to SNU)
35	Battery under-voltage recovery threshold	52	When the battery is under voltage, the battery voltage needs to be greater than the threshold to restore the AC output of the battery inverter. Setting range: 44 V–54.4 V
37	Recharge voltage threshold for fully charged battery	52	Inverter stops charging when the battery is full. Inverter resumes charging when the battery voltage below this value. Setting range: 44V~54V.
38	AC output voltage	220	Setting range: 200/208/220/230/240Vac
39	Charge current limitine method (when BMS is enabled)	LCSET	The maximum battery charge current is not greater than the set value of [item 07]
		38 LCBMS (default)	The maximum battery charge current is not greater than the maximum value of BMS
		38 LCINV	The maximum battery charge current is not greater than the logical judgment value of inverter
40	Period-1 battery charge start time	00:00:00	Setting range: 00:00:00–23:59:00
41	Period-1 battery charge end time	00:00:00	Setting range: 00:00:00–23:59:00
42	Period-2 battery charge start time	00:00:00	Setting range: 00:00:00–23:59:00
43	Period-2 battery charge end time	00:00:00	Setting range: 00:00:00–23:59:00
44	Period-3 battery charge start time	00:00:00	Setting range: 00:00:00–23:59:00
45	Period-3 battery charge end time	00:00:00	Setting range: 00:00:00–23:59:00
46	Timed battery charge function	DIS (default)	Disable the function
		ENA	Enable this function, AC output source mode will switch to SBU, utility charging the battery and carry load only in charging time slot which user set or the battery is under voltage. If time slot discharging function is also enabled, AC output source mode will switch to UTI, utility charging the battery only in charging time slot which user set, and switch to battery charging in discharging time slot or utility power failure. (pure off-grid mode only)

ID	Parameter	Option	Description
47	Period-1 battery discharge start time	00:00:00	Setting range: 00:00:00–23:59:00
48	Period-1 battery discharge end time	00:00:00	Setting range: 00:00:00–23:59:00
49	Period-2 battery discharge start time	00:00:00	Setting range: 00:00:00–23:59:00
50	Period-2 battery discharge end time	00:00:00	Setting range: 00:00:00–23:59:00
51	Period-3 battery discharge start time	00:00:00	Setting range: 00:00:00–23:59:00
52	Period-3 battery discharge end time	00:00:00	Setting range: 00:00:00–23:59:00
53	Timed battery discharge function	DIS (default)	Disable the function
		ENA	Enable this function, AC output source mode will switch to UTI , battery discharging only in discharging time slot which user set or utility is not available.
54	Local date	00:00:00	Year/Month/Day Setting range: 00:01:01–99:12:31
55	Local time	00:00:00	Setting range: 00:00:00–23:59:59
57	Stop charging current	2	The charge stops when the charge current is less than the set value (unit: A)
58	Discharging alarm SOC	15	Triggers an alarm when the battery SOC is less than the set value. (unit:%)
59	Discharging cutoff SOC	5	Stops discharging when the battery SOC is less than the set value. (unit:%)
60	Charging cutoff SOC	100	Stops charging when the battery SOC is higher than the set value. (unit:%)
61	Switching to utility SOC	10	Switch to utility power when the battery SOC is less than this setting. (unit:%)
62	Switching to inverter SOC	100	Switches to inverter output mode when SOC is higher than this setting. (unit:%)
63	N-PE bonding automatic switching function	DIS (default)	Disable auto N-PE connection switch
		ENA	Enable auto N-PE connection switch

### 5.3、 AC output mode

The AC output mode corresponds to parameter setting item 01 and 34, which allows the user to set the AC output power source manually.

- Utility Priority Output 01 UTI (default)**

Utility at first priority, utility and solar provide power to load at the same time when solar is available, battery will provide power to load only when utility power is not available.(Priority: utility>solar>battery)

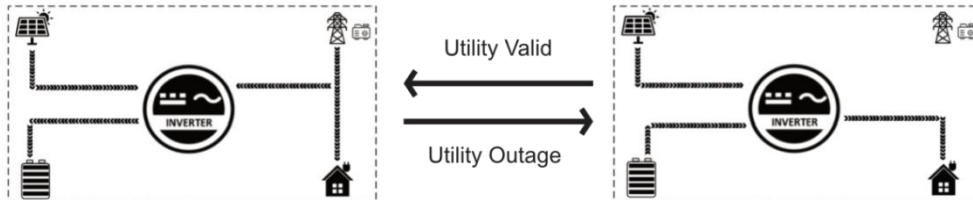

- Solar and Utility Hybrid Output**

In UTI mode, when not connected to the battery or when the battery is full, the solar and the utility supply power to the load at the same time.(Priority: solar>utility>battery)



- Solar Priority Output 01 SOL**

Solar provides power to the loads as first priority.If solar is not available, the utility grid will provide power to the loads. This mode maximizes solar energy while maintaining battery power and is suitable for areas with relatively stable power grids.(Priority: solar>utility>battery)

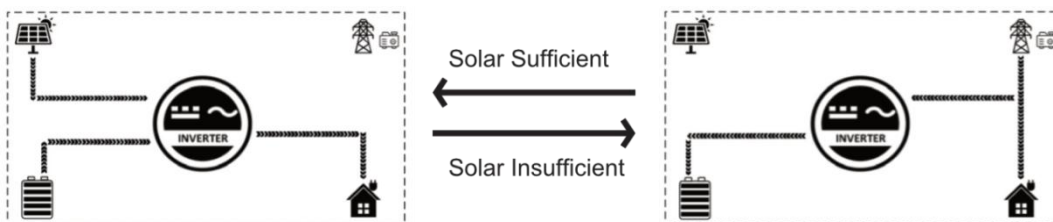

- Inverter Priority Output 01 SbU**

Solar provides power to the loads as first priority.If solar is not sufficient or not available, the battery will be used as a supplement to provide power to the loads. When the battery voltage reaches the value of parameter 04 (Voltage point of battery switch to utility )will switch to utility to provide power to the load,This model makes maximum use of DC energy and is used in areas where the grid is stable. (Priority: solar>battery>utility)

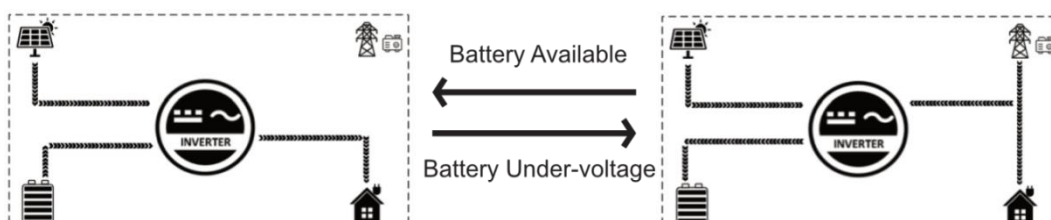

## 5.4. Battery charging mode

The charging mode corresponds to parameter setting item 06, which allows the user to set the charging mode manually.

- **Hybrid Charging SNU (default)**

Solar and utility charging the battery at the same time, solar at the first priority, utility power as a supplement

when solar power is not sufficient. This is the fastest way to charge and is suitable for areas with low power supply, providing customers with sufficient back-up power. (Source priority: solar > utility)

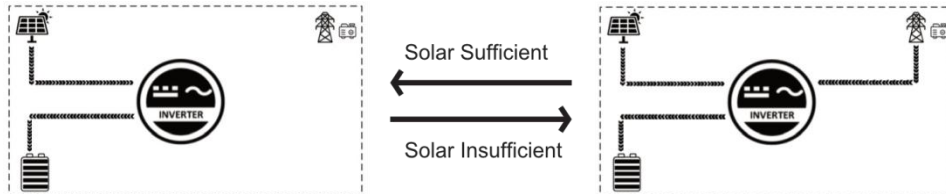

- **Only Solar Charging OSO**

Solar charging only, no mains charging is activated. This is the most energy-efficient method, with all the battery power coming from solar energy, and is usually used in areas with good radiation conditions.

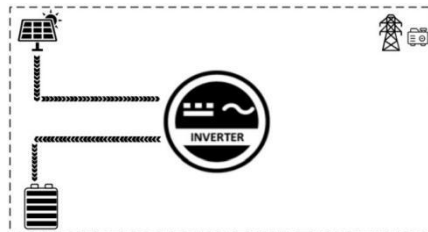

## 5.5 Timed charge/discharge function

The DW series is equipped with a time-slot charging and discharging function, which allows users to set different charging and discharging periods according to the local peak and valley tariffs, so that the utility power and PV energy can be used rationally.

When mains electricity is expensive, the battery inverter is used to carry the load; when the mains electricity is cheap, the mains electricity is used to carry the load and charge, which can help customers to save electricity costs to the greatest extent.

The user can turn on/off the time-slot charging/discharging function in setup menu parameter 46 and 53. And set charging and discharging slot in parameter 40-45, 47-52. Below are examples for users to understand the function.

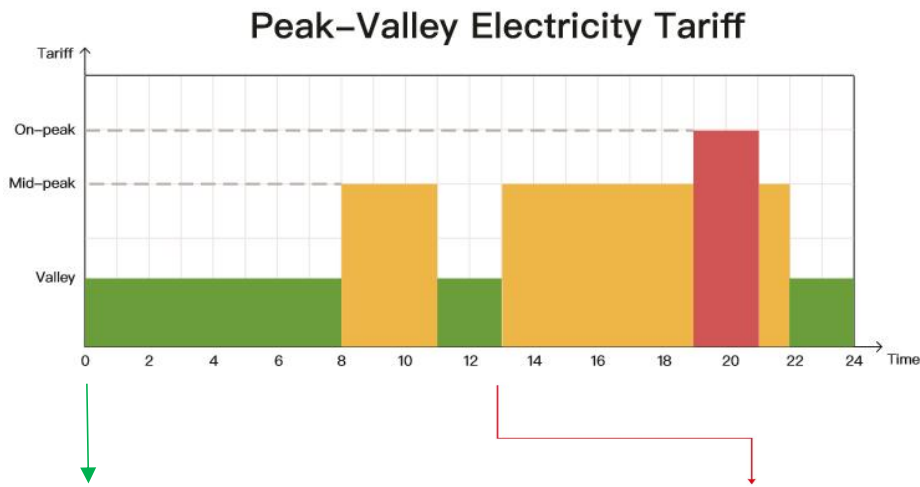

### Timed charge and loading function



With 3 definable periods, users can freely set the mains charge/loading period in the range of 00:00–23:59. During the period set by the user, in case of PV energy output, it will be used first; in case of no PV energy output or lack of PV energy, mains will be used as a supplement.

### Timed battery discharge function



With 3 definable periods, users can freely set the battery discharge period in the range of 00:00–23:59. During the period set by the user, the inverter will first use the battery inverter to load; if the battery power is insufficient, the inverter will automatically switch to mains to ensure stable operation of the load.

## 5.6 Battery parameters

- Lead-acid battery

Parameter/Battery Type	Sealed Lead-acid Battery	Gel lead-acid battery	Flooded Lead-acid Battery	User-defined Battery
	SLD	GEL	FLD	USER
Over-voltage cut-off voltage	60 V	60 V	60 V	60 V
Equalizing charge voltage	58 V	56.8 V	58 V	40 V-60 V (settable)
Boost charge voltage	57.6 V	56.8 V	57.6 V	40 V-60 V (settable)
Floating charge voltage	55.2 V	55.2 V	55.2 V	40 V-60 V (settable)
Under-voltage alarm voltage	44 V	44 V	44 V	40 V-60 V (settable)
Under-voltage disconnect voltage	42 V	42 V	42 V	40 V-60 V (settable)
Discharge limit voltage	40 V	40 V	40 V	40 V-60 V (settable)
Over-discharge delay time	5s	5s	5s	1s-30s (settable)
Equalizing charge duration	120 min	-	120 min	0 min-600 min (settable)
Equalizing charge cycle	30 d	-	30 d	0 d-250 d (settable)
Boost charge cycle	120 min	120 min	120 min	10 min-600 min (settable)

**NOTICE**

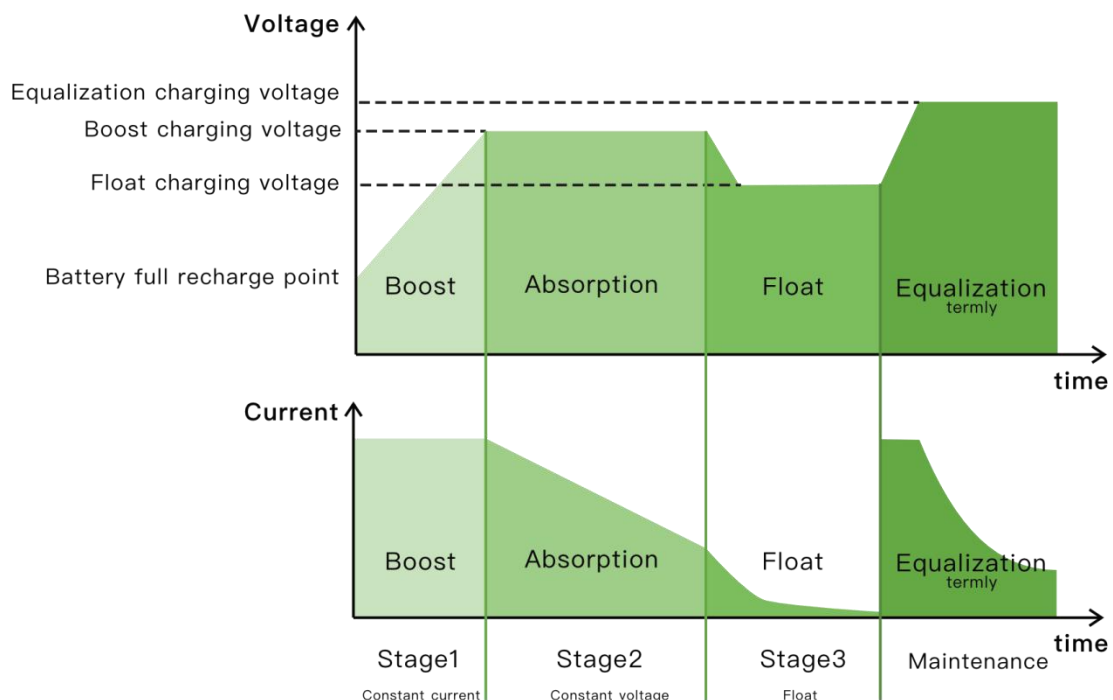

• Li-ion battery

Parameter/Battery Type	Ternary Li-ion Battery		LFP Battery			User-defined Battery
	N13	N14	L16	L15	L14	USER
Over-voltage cut-off voltage	60 V	60 V	60 V	60 V	60 V	60 V
Equalizing charge voltage	-	-	-	-	-	40 V-60 V (settable)
Boost charge voltage	53.2 V	57.6 V	56.8 V	53.2 V	49.2 V	40 V-60 V (settable)
Floating charge voltage	53.2 V	57.6 V	56.8 V	53.2 V	49.2 V	40 V-60 V (settable)
Under-voltage alarm voltage	43.6 V	46.8 V	49.6 V	46.4 V	43.2 V	40 V-60 V (settable)
Under-voltage disconnect voltage	38.8 V	42 V	48.8 V	45.6 V	42 V	40 V-60 V (settable)
Discharge limit voltage	36.4 V	39.2 V	46.4 V	43.6 V	40.8 V	40 V-60 V (settable)
Over-discharge delay time	30s	30s	30s	30s	30s	1s-30s (settable)
Equalizing charge duration	-	-	-	-	-	0 min-600 min (settable)
Equalizing charge cycle	-	-	-	-	-	0 d-250 d (settable)
Boost charge cycle	120 min (settable)	120 min (settable)	120 min (settable)	120 min (settable)	120 min (settable)	10 min-600 min (settable)

**NOTICE**

If no BMS is connected, the inverter will charge according to the battery voltage with a preset charging curve. When the inverter communicates with the BMS, it will follow the BMS instructions to perform a more complex stage charging process.

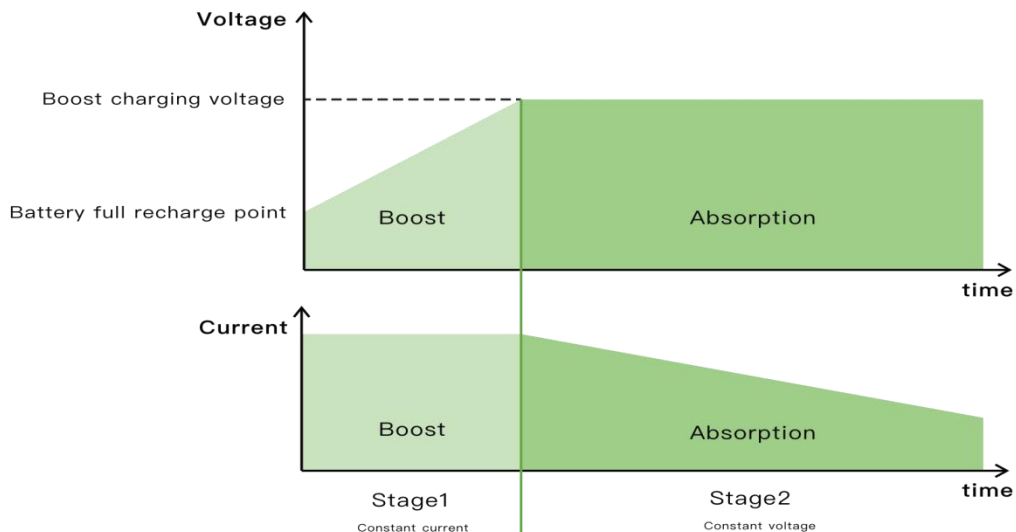

# 6.Communication

## 6.1、 Overview

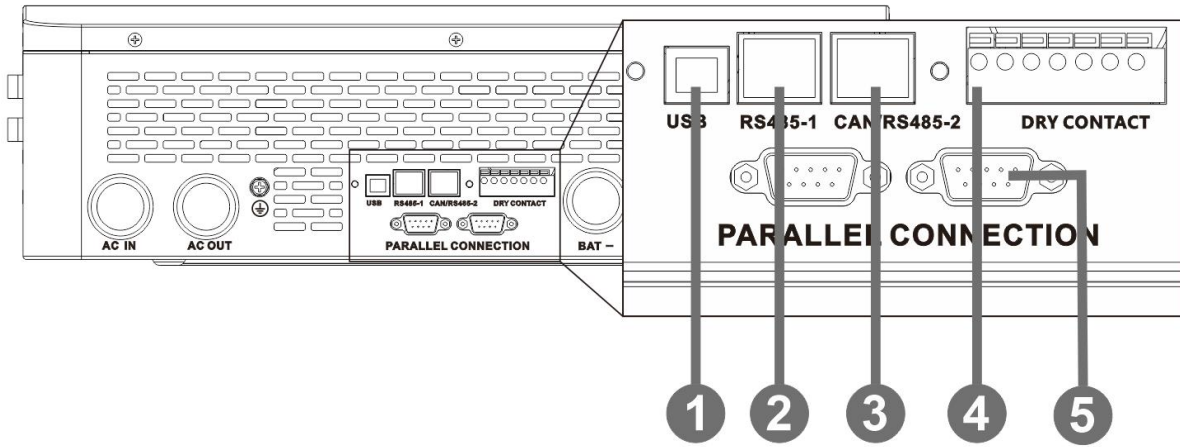

1	USB-B Port	2	RS485-1 Port	3	RS485-2 Port
4	Dry contact port	5	Parallel connection port		

## 6.2、 USB-B Port

The user can read and modify device parameters through this port by using the host software. Please contact us for the host software installation package if you require one.

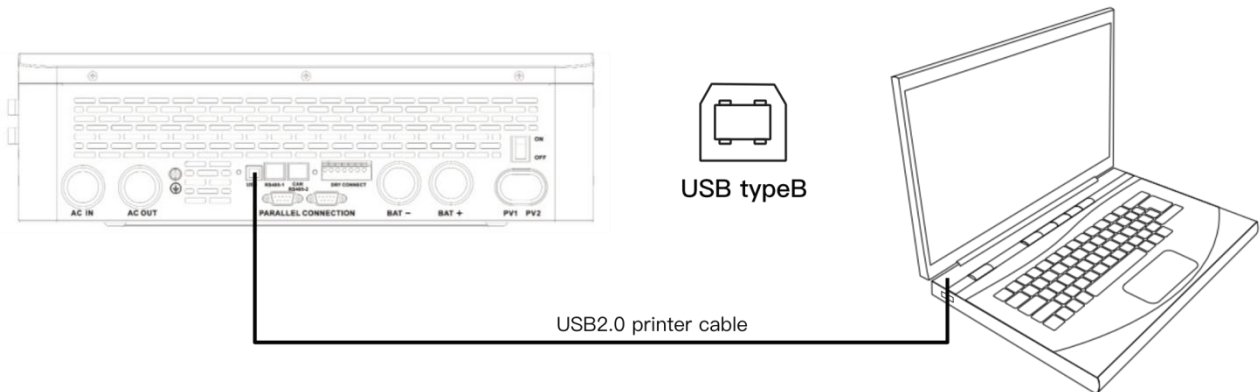

### 6.3、 RS485-1 Port

The RS485-1 port is used to connect to the Wi-Fi/GPRS data acquisition module, which allows the user to view the operating status and parameters of the inverter via the mobile phone APP.

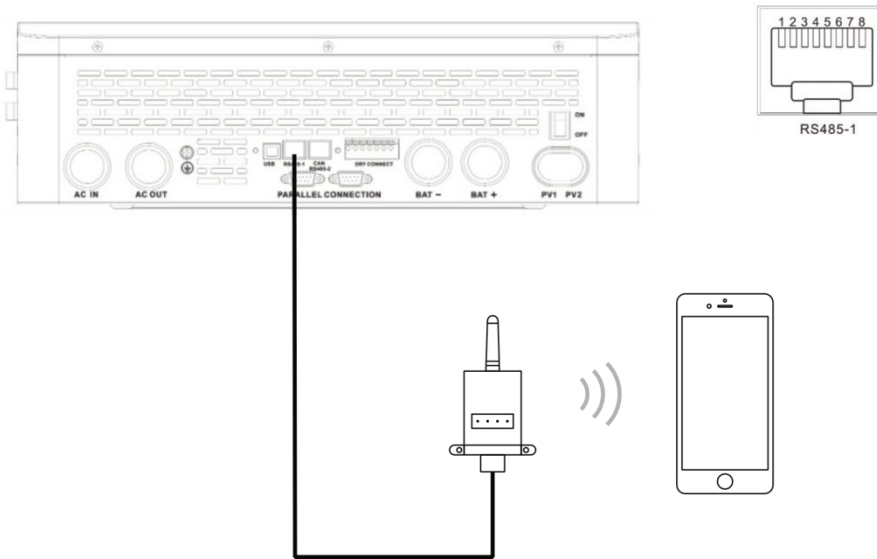

RJ45	Definition
Pin 1	5V
Pin 2	GND
Pin 3	/
Pin 4	/
Pin 5	/
Pin 6	/
Pin 7	RS485-A
Pin 8	RS485-B

### 6.4、 CAN/RS485-2 Port

The RS485-2 port is used to connect to the BMS of Li-ion battery.

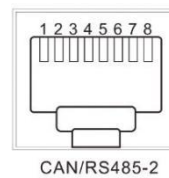

RJ45	Definition
Pin 1	5V
Pin 2	GND
Pin 3	/
Pin 4	CANH
Pin 5	CANL
Pin 6	/
Pin 7	RS485-A
Pin 8	RS485-B

**NOTICE**

If you need the inverter to communicate with the lithium battery BMS, please contact us for the communication protocol or to upgrade the inverter to the corresponding software program.

## 6.5、 Dry contact

Dry contact port with 4 functions:

1. Remote switch on/off
2. Switching signal output
3. Battery temperature sampling
4. Generator remote start/stop

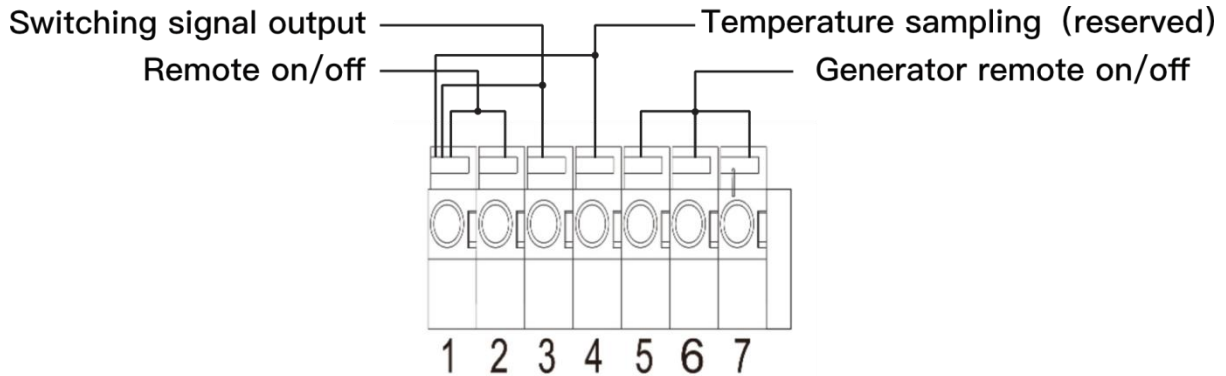

Function	Description
Remote ON/OFF	When pin 1 is connected to pin 2, the inverter will turn off the AC output. When disconnected, the inverter is in normal output.
ON/OFF signal output	When the battery voltage reaches the discharge limit voltage (parameter 15), the voltage between pin 3 and pin 1 is 0 V. When the battery is in normal charge or discharge status, the voltage between pin 3 and pin 1 is 5 V.
Temperature sampling (reserved)	Pins 1 and 4 can be used for battery temperature sampling compensation.
Remote generator start/stop	When the battery voltage reaches the under-voltage alarm voltage (parameter 14) or the voltage threshold for mains to switch to the battery (parameter 04), pins 6 to 5 are normally open, and pins 7 to 5 are normally closed. When the battery voltage reaches the voltage threshold for the battery to switch to mains (parameter 05), or the battery is fully charged, pins 6 to 5 are normally closed, and pins 7 to 5 are normally open. (5/6/7 pin output: 125 VAC/1 A, 230 VAC/1 A, and 30 VDC/1 A)



### NOTICE

If you need to use the remote start/stop function of the generator with dry contact, ensure that the generator has ATS and supports remote start/stop.

# 7. Fault and Remedy

## 7.1. Fault Code

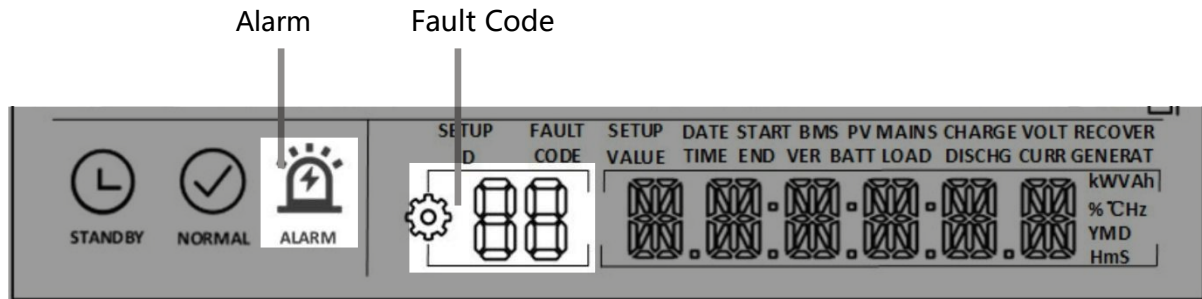

Fault Code	Meaning	Affect Output or Not	Instructions
01	BatVoltLow	Yes	Battery under-voltage alarm
02	BatOverCurrSw	Yes	Over-current software protection for average battery discharge current
03	BatOpen	Yes	Disconnected battery alarm
04	BatLowEod	Yes	Under-voltage battery discharge stop alarm
05	BatOverCurrHw	Yes	Battery over-current hardware protection
06	BatOverVolt	Yes	Charge over-voltage protection
07	BusOverVoltHw	Yes	Bus over-voltage hardware protection
08	BusOverVoltSw	Yes	Bus over-voltage software protection
09	PvVoltHigh	Yes	PV over-voltage protection
10	PvBoostOCSw	No	Boost over-current software protection
11	PvBoostOCHw	No	Boost over-current hardware protection
12	DWCommErr	Yes	DW communication fault of master and slave chips
13	OverloadBypass	Yes	Bypass overload protection
14	OverloadInverter	Yes	Inverter overload protection
15	AcOverCurrHw	Yes	Inverter over-current hardware protection

16	AuxDSpReqOffP WM	Yes	Slave chip OFF request fault
17	InvShort	Yes	Inverter short-circuit protection
18	Bussoftfailed	Yes	Bus soft-start failure
19	OverTemperMppt	No	PV heat sink over-temperature protection
20	OverTemperInv	Yes	Inverter heat sink over-temperature protection
21	FanFail	Yes	Fan fault
22	EEPROM	Yes	Memory fault
23	ModelNumErr	Yes	Model setting error
24	Busdiff	Yes	Positive and negative bus voltage imbalance
25	BusShort	Yes	Bus short-circuit
26	Rlyshort	Yes	Inverter AC output backward to bypass AC output
28	LinePhaseErr	Yes	Mains input phase error
29	BusVoltLow	Yes	Bus low-voltage protection
30	BatCapacityLow1	Yes	Alarm of battery capacity rate below 10% (taking effect after BMS communication is successful)
31	BatCapacityLow2	No	Alarm of battery capacity rate below 5% (taking effect after BMS communication is successful)
32	BatCapacityLowSt op	Yes	Battery low-capacity OFF (taking effect after BMS communication is successful)
33	CtrlCanCommErr	Yes	Parallel control can communication fault
<b>34</b>	CanCommFault	Yes	Parallel can communication fault
<b>35</b>	ParaAddrErr	Yes	Parallel ID (communication address) setting error
<b>37</b>	ParaShareCurrErr	Yes	Parallel current sharing fault
<b>38</b>	ParaBattVoltDiff	Yes	Large battery voltage difference in parallel mode
<b>39</b>	ParaAcSrcDiff	Yes	Inconsistent mains input source in parallel mode

40	ParaHwSynErr	Yes	Hardware synchronization signal error in parallel mode
41	InvDcVoltErr	Yes	Inverter DC voltage error
42	SysFwVersionDiff	Yes	Inconsistent system firmware version in parallel mode
43	ParaLineContErr	Yes	Parallel connection fault
44	Serialnumbererror	Yes	Failure to set the serial number before leaving factory
45	Errorsettingofsplit-phasemode	Yes	Setting error of setting items in parallel mode
58	BMSComErr	No	BMS communication fault
60	BMSUnderTem	No	BMS under-temperature alarm (taking effect after BMS communication is successful)
61	BMSOverTem	No	BMS over-temperature alarm (taking effect after BMS communication is successful)
62	BMSOverCur	No	BMS over-current alarm (taking effect after BMS communication is successful)
63	BMSUnderVolt	No	BMS under-voltage alarm (taking effect after BMS communication is successful)
64	BMSOverVolt	No	BMS over-voltage alarm (taking effect after BMS communication is successful)

## 7.2、 Troubleshooting

Fault Code	Meaning	Cause	Remedy
/	No screen display	There is no power input, or the device switch at its bottom is not turned on	Check if the battery air-switch or PV air-switch has been closed; check if the switch is in "ON"; press any button on the screen to exit the screen sleep mode.
01	Battery under-voltage	The battery voltage is lower than the value set in parameter [14]	Charge the battery until the battery voltage exceeds the value set in parameter [14].
03	Disconnected battery	The battery is not connected, or the BMS of the lithium-ion battery is in the discharge protection state	Check if the battery is reliably connected; check if the circuit breaker of the battery is off; ensure that the BMS of the lithium-ion battery can communicate normally.
04	Battery over-discharge	The battery voltage is lower than the value set in parameter 12	Manual reset: Turn off the power, and restart Automatic reset: Charge the battery until the battery voltage is higher than the value set in parameter [35]
06	Rechargeable battery overvoltage protection	The battery is in the overvoltage state	Manually turn off the power, and restart Check if the battery voltage exceeds the limit. If the limit is exceeded, discharge the battery until the voltage is below the overvoltage recovery threshold of the battery
13	Bypass overload (software detection)	The output power or current of the bypass is overloaded within a certain period	Reduce the load power, and restart the device. For more details, please refer to item 11 in <i>Protection Function</i>
14	Inverter overload (software detection)	The output power or current of the inverter is overloaded within a certain period	

19	Over-high temperature of the heat sink for PV input (software detection)	The temperature of the heat sink for PV input exceeds 90°C for 3s	Wait until the temperature of the heat sink is below the over-temperature recovery temperature, when charge and discharge return to normal
20	Over-high temperature of the heat sink for inverter output (software detection)	The temperature of the heat sink for inverter output exceeds 90°C for 3s	
21	Fan fault	Software detection finds the fan has a fault	Shut down, manually flick the fan, and check if any foreign objects are blocking it
26	AC input relay short-circuit	Stuck relay for AC output	Manually shut down, and restart. If the fault occurs again after restarting, contact the after-sales service personnel to repair the machine
28	Mains input phase fault	The phase of AC input is inconsistent with that of AC output	Ensure that the phase of AC input is the same as that of AC output. For example, if the output is in the split-phase mode, the input shall also be in the split-phase mode.

**NOTICE**

If you encounter a fault with the product that cannot be solved by the methods in the table above, please contact our after-sales service for technical support and do not disassemble the equipment yourself.

## 8. Protection and Maintenance

### 8.1. Protection features

No	Protection Feature	Instruction
1	PV input current/power limiting protection	When the charging current or power of the PV array configured exceeds the PV input rated value, the inverter will limit the input power and charge at the rated.
2	PV input over-voltage	If the PV voltage exceeds the maximum value allowed by the hardware, the machine will report a fault and stop the PV boost to output a sinusoidal AC wave.
3	PV night reverse current protection	At night, the battery is prevented from discharging through the PV module because the battery voltage is greater than the voltage of PV module.
4	AC input over-voltage protection	When the AC input voltage of each phase exceeds 280V, the mains charging will be stopped and switched to the inverter mode.
5	AC input under-voltage protection	When the AC input voltage of each phase below 170V, the utility charging will be stopped and switched to the inverter mode.
6	Battery over-voltage protection	When the battery voltage reaches the over-voltage cut-off point, the PV and the utility will automatically stop charging to prevent the battery from being overcharged and damaged.
7	Battery under-voltage protection	When the battery voltage reaches the under-voltage cut-off point, the inverter will automatically stop the battery discharge to prevent damage from over-discharging the battery.
8	Battery over-current protection	After a period when the battery current exceeds that allowed by the hardware, the machine will switch off the output and stop discharging the battery.
9	AC output short-circuit protection	When a short-circuit fault occurs at the load output terminal, the AC output is immediately turned off and turned on after 1 second. If the output load terminal is still short-circuited after 3 attempts, the inverter must be manually restarted after first removing the short-circuit fault from the load before the normal output can be restored.
10	Heat sink over-temperature protection	When the internal temperature of the inverter is too high, the inverter will stop charging and discharging; when the temperature returns to normal, the inverter will resume charging and discharging.
11	Inverter over-load protection	After triggering the overload protection the inverter will resume output after 3 minutes, 5 consecutive overloads will switch off the output until the inverter is restarted. (102% < load < 110%) ±10%: error and output shutdown after 5min; (110% < load < 125%) ±10%: error and output shutdown after 10s. Load > 125% ±10%: error reported and output switched off after 5s.

12	AC output reverse	Prevents AC back flow from the battery inverter to the bypass AC input.
13	Bypass over-current protection	Built-in AC input over-current protection circuit breaker.
14	Bypass phase inconsistency protection	When the phase of the bypass input and the phase of the inverter split do not match, the inverter disables switching to the bypass output to prevent the load from dropping out or short-circuiting when switching to the bypass.

## 8.2、 Maintenance

To maintain optimum and long-lasting working performance, we recommend that the following items are checked twice a year.

1. Ensure that the airflow around the inverter is not blocked and remove any dirt or debris from the radiator.
2. Check that all exposed conductors are not damaged by sunlight, friction with other surrounding objects, dry rot, insect or rodent damage, etc. The conductors need to be repaired or replaced if necessary.
3. Verify that the indications and displays are consistent with the operation of the equipment, note any faults or incorrect displays and take corrective action if necessary.
4. Check all terminals for signs of corrosion, insulation damage, high temperatures or burning/discolouration and tighten terminal screws.
5. Check for dirt, nesting insects and corrosion, clean anti insects net as required.
6. If the lightning arrester has failed, replace the failed arrester in time to prevent lightning damage to the inverter or other equipment of the user.



Make sure that the inverter is disconnected from all power sources and that the capacitors are fully discharged before carrying out any checks or operations to avoid the risk of electric shock.

The Company shall not be liable for damage caused by :

1. Damage caused by improper use or use in a wrong location.
2. Photovoltaic modules with an open circuit voltage exceeding the maximum permissible voltage.
3. Damage caused by the operating temperature exceeding the restricted operating temperature range.
4. Dismantling and repair of the inverter by unauthorised persons.
5. Damage caused by force majeure: damage during transport or handling of the inverter.

## 9. Datasheet

Model	DWA-8KLP1-EU	DWA-10KLP1-EU	Settable
<b>INVERTER OUTPUT</b>			
Rated Output Power	8,000W	10,000W	
Max.Peak Power	12,000W	15,000W	
Rated Output Voltage	230Vac (Single phase)		Y
Load Capacity of Motors	5HP	6HP	
Rated AC Frequency	50/60Hz		Y
Waveform	Pure Sine Wave		
Switch Time	10ms (typical)		
Parallel capacity	1-6 Units		
Overload	<p>After triggering the overload protection the inverter will resume output after 3 minutes, 5 consecutive overloads will switch off the output until the inverter is restarted.</p> <p>(102%&lt;load&lt;110%) ±10%: error and output shutdown after 5mins;</p> <p>(110% &lt; load &lt; 125%) ±10%: error and output shutdown after 10s.</p> <p>Load &gt; 125% ±10%: error reported and output switched off after 5s.</p>		
<b>BATTERY</b>			
Battery Type	Li-ion / Lead-Acid / User Defined		Y
Rated Battery Voltage	48Vdc		
Voltage Range	40-60Vdc		Y
Max.MPPT Charging Current	180A	200A	Y
Max.Mains/Generator Charging Current	100A	120A	Y
Max.Hybrid Charging Current	180A	200A	Y
<b>PV INPUT</b>			
Num. of MPP Trackers	2		
Max.PV array power	5,500W+5,500W		
Max.input current	22/22A		
Max.Voltage of Open Circuit	500Vdc+500Vdc		
MPPT Voltage Range	125-425Vdc		
<b>MAINS / GENERATOR INPUT</b>			
Input Voltage Range	90-275Vac		
Frequency Range	50/60Hz		

Bypass Overload Current	63A	
<b>EFFICIENCY</b>		
MPPT Tracking Efficiency	99.9%	
Max. Battery Inverter Efficiency	92%	
<b>GENERAL</b>		
Dimensions	620*445*130mm (2*1.46*0.4ft)	
Weight	27kg (59lb)	
Protection Degree	IP20	
Operating Temperature Range	-10~55°C, >45°C derated (14~131°F, >113°F derated)	
Noise	<60dB	
Cooling Method	Internal Fan	
Warranty	2 Years	
<b>COMMUNICATION</b>		
Embedded Interfaces	RS485 / CAN / USB / Dry contact	Y
External Modules (Optional)	Wi-Fi / GPRS	Y
<b>CERTIFICATION</b>		
Safety	IEC62109-1, IEC62109-2	
EMC	EN61000-6-1, EN61000-6-3, FCC 15 class B	
RoHS	Yes	