



# User Manual

## Integrated energy storage cabinet

### HZEB-HCT-100

V1.0.1.20240814

## Contents

● Foreword .....	4
●   • Applicable product .....	4
●   • Applicable personnel .....	4
●   • Legal statement .....	4
●   • Other statements .....	4
●   • Revision history .....	5
● Safety .....	6
●   • Safety instruction .....	6
●   • Personal safety .....	6
●    • Personnel requirement .....	6
●    • Safety warning operation .....	6
●   • Electrical safety .....	7
●    • Electric safety .....	7
●    • ESD safety .....	7
●    • Precautions for battery pack .....	7
●   • Environmental safety .....	7
●    • Escape way requirements .....	7
●    • Moisture protection .....	7
●   • Safety of machinery .....	7
●    • General requirement .....	8
●    • Requirements for heavy object moving .....	8
●    • Forklift and lifting requirements .....	8
●   • Specification for live test .....	8
●    • Live line measurement .....	8
●    • Use of measuring equipment .....	8
●   • Equipment safety .....	8
●   • Product disposal .....	9
● Product Introduction .....	9
●   • Energy storage system introduction .....	9
●   • Product function .....	9
●   • Product characteristics .....	10
●   • Product parameters .....	10
●   • Dimension and layout .....	11
●    • Product dimension .....	11
●    • Product layout .....	11
●   • Introduction of product components .....	13
●    • Battery pack .....	13
●    • High-voltage cluster control box .....	14
●    • Thermal management system .....	18
●    • Fire protection system .....	20
●   • Working principle .....	27
●    • Single machine topology structure .....	27
●    • Typical application scenario .....	27
● Transportation requirement .....	29
●   • Moving requirement .....	29
●   • Transportation requirement .....	29
● Storage requirements .....	31
●   • Energy storage system storage (excluding battery pack) .....	31
●   • Battery pack storage .....	31
●   • Storage environment requirements .....	32
● Installation site requirement .....	33
●   • Location requirement .....	33
●   • Foundation requirements .....	34
●   • Forklift requirements .....	35
●   • Lifting requirements .....	35
● Equipment installation .....	37
●   • Preparation before installation .....	37
●   • Product installation .....	38
● Cable installation .....	40

---

- Prepare the cable ..... 40
- Installation of battery cabinet cables .....40
- System power on ..... 45
  - Inspection before powering on .....45
  - Power on procedures ..... 45
  - AC-side power on .....46
  - DC-side power on .....46
- System power off .....47
  - Issue a stop work command ..... 47
  - Energy storage system power off .....47
  - AC distribution power off ..... 47
- System maintenance ..... 48
  - Maintenance instruction ..... 48
  - Maintenance precautions .....48
  - Maintenance work ..... 48

## ● Foreword

This Manual mainly introduces the HZEB-HCT-100 product of Vesol. HZEB-HCT-100 is a lithium ironphosphate integrated battery energy storage system. Please read this manual carefully before installing and using the product, understand the safety information and be familiar with the relevant information, and follow the instructions carefully during the installation process. If you have any confusion, please contact the supplier for advice and instructions.

### • Applicable product

This Manual applies to the following model:

HZEB-HCT-100

※ In this Manual, unless otherwise specified, any reference to "battery" or "battery pack" refers to the product of that model.

### • Applicable personnel

This Manual is only applicable to the professionals who are familiar with local regulations, standards, and electrical systems, have received professional training, and are familiar with the relevant knowledge of the product. Including but not limited to:

Technical support engineer

Installation engineer

Commissioning engineer

Electrical engineer

Maintenance engineer

### • Legal statement

The copyright of this Manual belongs to Vesol. Without the prior written authorization of Vesol, no part of this Manual may be extracted, duplicated, translated, annotated or copied in any form or manner.

All rights are reserved by Vesol.

Please note that our company may make modifications to contents of this Manual without prior notice. If any changes are made to its information, we will not notify you separately.

### • Other statements

Before transporting, storing, installing, operating, using, or maintaining the equipment, please read this Manual thoroughly. Operate strictly according to the Manual and adhere to all safety precautions indicated on the equipment and in the Manual. In this Manual, "Equipment" refers to the products, software, components, spare parts, and/or services related to this Manual; "the Company" refers to the manufacturer (producer), seller, or service provider of the equipment; and "You" refers to the entity responsible for transporting, storing, installing, operating, using, or maintaining the equipment.

The "Danger," "Warning," and "Caution" items in the Manual do not represent all the safety measures that must be followed. You must also comply with relevant international, national, or regional standards, as well as industry practices. The Company assumes no liability for any damages resulting from non-compliance with

safety operation requirements or violations of design, production, and equipment safety standards.

This equipment should be used in an environment that meets the design specifications. Failure to do so may result in equipment faults, functional abnormalities, or component damage, which will not be covered by the equipment's quality warranty. Additionally, the Company will not be liable for any personal injury, property damage, or other losses that may arise from such conditions.

All activities, including transportation, storage, installation, operation, use, and maintenance, must comply with applicable laws, regulations, standards, and codes.

Reverse engineering, decompiling, disassembling, modifying, implanting, or otherwise studying the internal logic of the equipment, obtaining the software source code, or infringing on intellectual property is prohibited. Additionally, the results of any performance testing of the equipment's software must not be disclosed.

The Company shall not be held responsible for any of the following situations or their consequences:

- Damage to the equipment caused by earthquakes, floods, volcanic eruptions, landslides, lightning strikes, fires, war, armed conflicts, typhoons, hurricanes, tornadoes, extreme weather, or other force majeure events;
- Operating outside the conditions specified in this Manual;
- The installation and usage environment does not meet relevant international, national, or regional standards;
- Installation and use by unqualified personnel;
- Failure to operate according to the instructions and safety warnings provided in the product and documentation;
- Unauthorized disassembly, modification of the product, or alteration of the software code;
- Damage caused by transportation conducted by you or a third party you have authorized;
- Damage resulting from storage conditions that do not meet the requirements specified in the product documentation;
- Materials and tools provided by you that do not meet local laws, regulations, and relevant standards;
- Damage caused by your or a third party's negligence, intentional actions, gross misconduct, improper operation, or reasons not attributable to our company.

- **Revision history**

The latest version in the "Revision history" contains updates from all previous versions of this Manual.

V1. 0. 0. 20241024

- First issue.

## ● Safety

### • Safety instruction

Before proceeding with any work, please read all safety instructions carefully and follow them when operating the battery.

Incorrect operation may result in:

- Injury or death of operators or third parties.
- Damage to the system hardware

Skills that qualified personnel shall have:

- Training in installation, debugging, and hazard handling of electrical system
- Understanding of this Manual and other related documents
- Understanding of local regulations and directives

This Manual may use the following symbols to highlight information, and their meanings are as follows:



Indicates a hazardous situation that, if not avoided, will result in death or serious injury.



Caution: Indicates possible damage or injury.



Indicates potential risks of equipment damage or safety warnings. Failure to avoid these risks may result in equipment damage, data loss, reduced performance, or other unforeseen outcomes.

### • Personal safety



Do not perform installation, maintenance, or repair operations while the equipment is energized! Ensure that at least two personnel are present on-site during maintenance or repair activities.

#### • Personnel requirement

- Only professional electricians or qualified personnel are authorized to perform operations on this product.
- Operators should be thoroughly familiar with the structure and operating principles of the entire energy storage system.
- Operators should be thoroughly familiar with this Manual.
- Operators should be thoroughly familiar with the relevant standards of the country/region where the project is located.

#### • Safety warning operation

When performing installation, routine maintenance, or repairs on the battery pack, to prevent unauthorized personnel from coming near, making incorrect operations, or causing accidents, please follow these warning procedures:

- Place clear signs in front of and behind the battery pack and at the switches to prevent accidental switching.

- Install warning signs or safety barriers near the operating area.
- After completing maintenance or repairs, always remove the cabinet door key and store it securely.
- **Electrical safety**



Do not perform installation while the equipment is energized. This can cause fire or personal injury.

- **Electric safety**
- Do not touch terminals or conductors connected to the power grid.
- Pay attention to all instructions or safety documentation related to connections with the power grid and adhere to the warning labels on the product.
- Follow the safety precautions listed in this Manual and other related documents for the equipment.
- Perform a preliminary visual inspection of the equipment before operation to check for damage or other hazards.
- Check that all external equipment and circuit connections are secure.
- Ensure the equipment is in a safe condition before operating.

- **ESD safety**

- Avoid unnecessary contact with circuit boards.
- Follow electrostatic discharge protection guidelines, such as wearing anti-static wrist straps.

- **Precautions for battery pack**

- There is a lethal high voltage between the positive and negative terminals of the energy storage battery pack.
- When maintaining the equipment, ensure that the connection between the energy storage inverter and the energy storage battery pack is completely disconnected.

- **Environmental safety**



Do not place the equipment in flammable, explosive, or dusty environments, as this may cause fire or explosion hazards.

- **Escape way requirements**

To ensure that staff can quickly evacuate the scene in case of an accident, please follow the below:

- Do not place flammable or explosive materials around the battery pack.
- Do not block or occupy escape routes with clutter or in any other manner.

- **Moisture protection**

- Do not use the product in environments exceeding the specified humidity levels.

- **Safety of machinery**



When performing work at heights, always wear safety helmets and other protective equipment, and secure yourself to stable structural components to prevent falls. Before installing equipment, ensure it is properly secured to avoid tipping, which could cause injuries or damage to personnel and equipment.

- **General requirement**

- During transportation and installation, any scratches must be promptly repaired. Do not allow scratched areas to remain exposed for extended periods.
- Unauthorized welding, cutting, or any other operations to the equipment are prohibited.
- Use tools correctly and ensure proper handling techniques.
- When working at height, use wooden or insulated ladders; do not use single-step ladders.
- When using a ladder, ensure it is placed on a stable, flat surface, and have someone hold the ladder while you work.

- **Requirements for heavy object moving**

- Prepare for load-bearing before moving heavy objects.
- When multiple people are involved in moving, distribute the load evenly to ensure balanced weight distribution.
- Wear protective gloves, safety shoes, and other safety gear when moving heavy objects.

- **Forklift and lifting requirements**

- When using a forklift, ensure the forks are in the center position before lifting to prevent tipping.
- Before moving, secure the equipment to the forklift with ropes. During movement, assign a dedicated person to supervise.
- Lifting personnel must complete and pass relevant training before being allowed to perform the work.
- Place warning signs and barriers to isolate the lifting area.
- The lifting conditions must meet the operational requirements
- Do not allow personnel to walk underneath during lifting operations.
- During lifting operations, ensure the angle of the lifting cables is less than 90°.

- **Specification for live test**



There is a lethal high voltage between the positive and negative terminals of the energy storage battery pack. Ensure that two people are involved in the operation to maintain safety.

- **Live line measurement**

The equipment contains high voltage, and accidental contact may result in fatal electric shock. Therefore, when performing live line measurements:

- ensure proper protective measures are in place (such as wearing insulated gloves and insulated footwear).

- **Use of measuring equipment**

When conducting electrical measurements, connections, trial runs, and other operations on equipment:

- Select high-quality measuring equipment that matches the range and conditions required for the site requirements.
- Ensure that the measuring equipment is connected and used correctly and according to standards to prevent hazards such as electrical arcs.

- **Equipment safety**



Fencing, walls, or other protective measures must be installed around the equipment. Safety warning signs should be posted to isolate the area, preventing unauthorized personnel from entering or causing accidental operations during equipment operation, thereby avoiding personal injury or property damage.

- The equipment installation layout must meet the installation protection requirements specified in local standards, including but not limited to GB 51048-2014 Design Specifications for Electrochemical Energy Storage Power Stations and NFPA 855 Standard for the Installation of Stationary Energy Storage Systems. Before installing, operating, or maintaining the battery, read the relevant instructions and follow the manufacturer's requirements.
- Please use the battery within the specified temperature range.
- If the battery is accidentally exposed to water, do not continue with the installation. Move it to a safe location and arrange for prompt disposal.
- Before installing the battery, check that the battery pack enclosure is free from damage or deformation.

- **Product disposal**



When disposing of the product, do not treat it as regular waste.

- The Company has priority rights for the recycling of discarded batteries.
- For discarded batteries not recycled by the Company, please contact a local authorized recycling organization or manufacturer for disposal and recycling.

**Note:** This Manual may not cover all possible situations during operation, maintenance, or repair. If you encounter circumstances not explained in the manual, please follow the relevant local regulations and standards and contact Yichun Vesol Manufacture and Trade Co., Ltd. promptly.

- **Product Introduction**

- **Energy storage system introduction**

Energy storage system refers to the process of storing energy through a medium or device and releasing it when needed. Energy storage system includes the input and output of energy and matter, energy conversion and storage equipment. Energy storage technology can be divided into physical energy storage, electrochemical energy storage, electromagnetic energy storage and other types.

Among them, electrochemical energy storage system is a system that uses electrochemical batteries as energy storage carriers and stores and releases cyclic electric energy through energy storage inverters. Its essence is to store electric energy into chemical energy, then release it through the mechanism of chemical batteries, and put it into the power grid to turn it back into electric energy. Compared with other energy storage technology routes, electrochemical energy storage system has the characteristics of high energy density, moderate response speed, wide application range, and easier mass production, installation and operation and maintenance, so it has excellent scale promotion potential.

Electrochemical energy storage includes lithium ion, sodium ion, liquid flow and other forms. Among them, lithium ion is the most mature and is the technical direction route with high market recognition.

In energy storage system, energy storage battery, as an energy storage device, plays a key role in adapting to various usage situations.

- **Product function**

The system is divided into a battery compartment and an external wall-mounted inverter. The internal control circuit of the inverter can send instructions to control the charging or discharging of the battery. The energy input and output of the energy storage system are both 400VAC AC. The maximum charging and discharging current of this system is 50A.

- **Battery charging:** The energy storage inverter (hereinafter referred to as PCS) is connected to the high-voltage cluster control box. Under the control of the control system, the PCS is controlled to charge the battery and store the excess energy in the battery.
- **Battery discharge:** When the power grid is insufficient to supply power to the load, the system needs to control the battery to supply power to the load through the inverter, and output the stored battery energy to the load through the PCS.

## • Product characteristics

The energy storage system is composed of lithium iron phosphate battery cells with high energy density, low cost and high safety, which are connected in a certain series and parallel manner. The system includes power supply and distribution system, battery management system, thermal management system, fire suppression system, etc. It has the characteristics of safety, reliability, rapid deployment and intelligent management; and can be widely used in various scenarios through various types of equipment. Comprehensive, multi-level battery warning and protection strategies, ensuring high safety

- Equipped with comprehensive communication and monitoring functions, ensuring continuous and stable operation for a long time
- A single stack can support up to 10 clusters in parallel (requires a suitable EMS)
- Equipped with automatic fire alarm and automatic fire extinguishing system inside the cabinet
- Equipped with an intelligent temperature control system inside the cabinet, minimizing the impact of external environmental conditions on the internal equipment and making the system suitable for a wide range of applications.

## • Product parameters

Model	HZEB-HCT-100
Cell type	LFP
Rated capacity	100.352kWh
Rated voltage	358.4V
Operating voltage range	302.4~403.2V
Rated current	140A (0.5C)
<b>Inverter Specifications (AC)</b>	
Rated Power	30kw
AC rated voltage	400V
wiring	3P4L+PE
Rated frequency	50Hz
AC maximum current	50A
<b>Specifications</b>	
weight	1432kg
Temperature range	-20°C~55°C
Humidity range	5%~90% (without condensation)
Protection level	IP54
Noise	80dB
Altitude	≤2000m
Cooling method	Intelligent air cooling

Table Product parameter

- **Dimension and layout**
- **Product dimension**

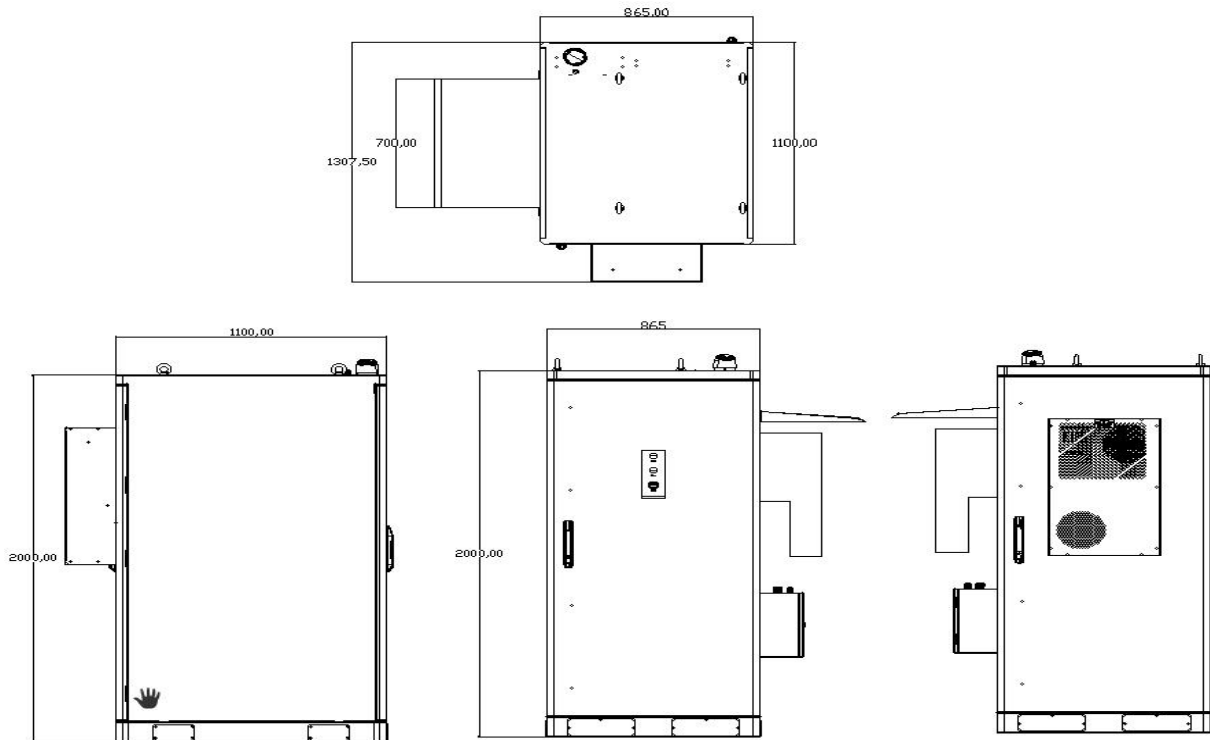

Figure Product dimension

## Product layout

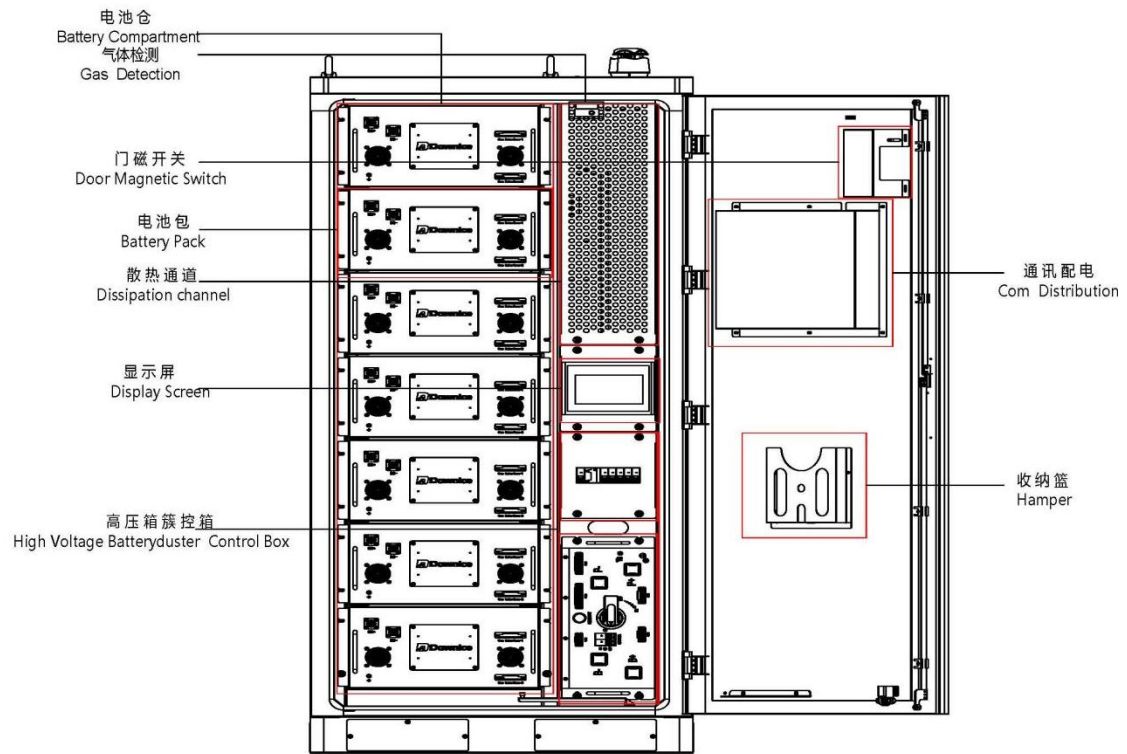

Figure Front layout

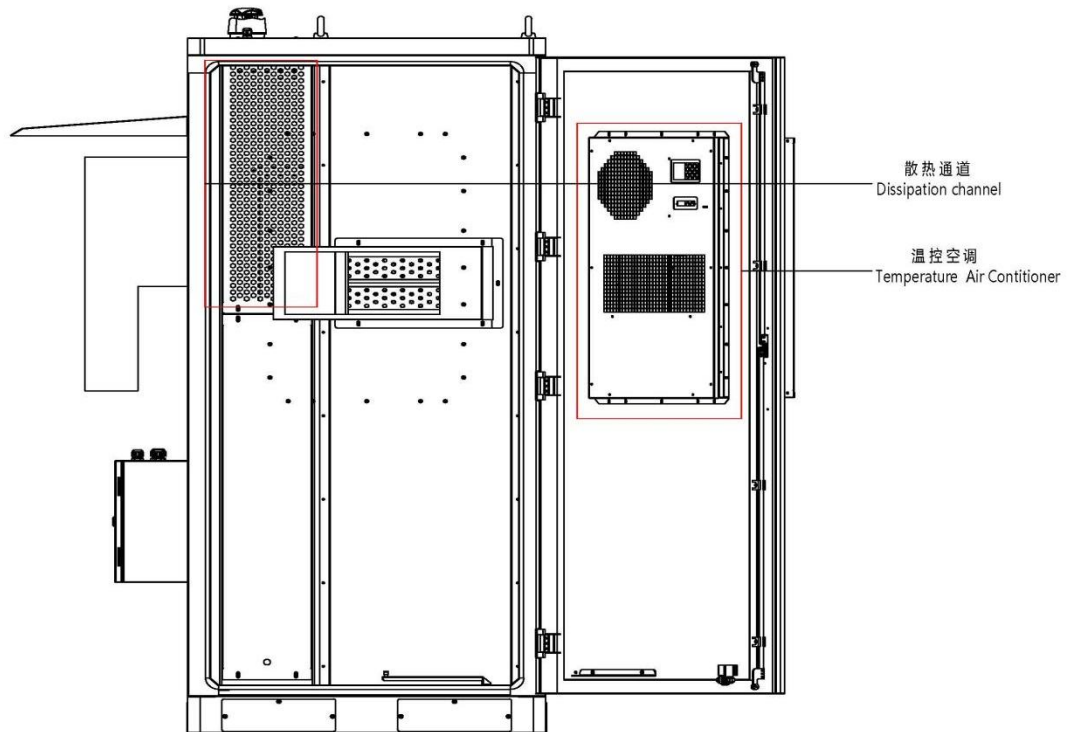

Figure Back layout

- **Introduction of product components**
- **Battery pack**

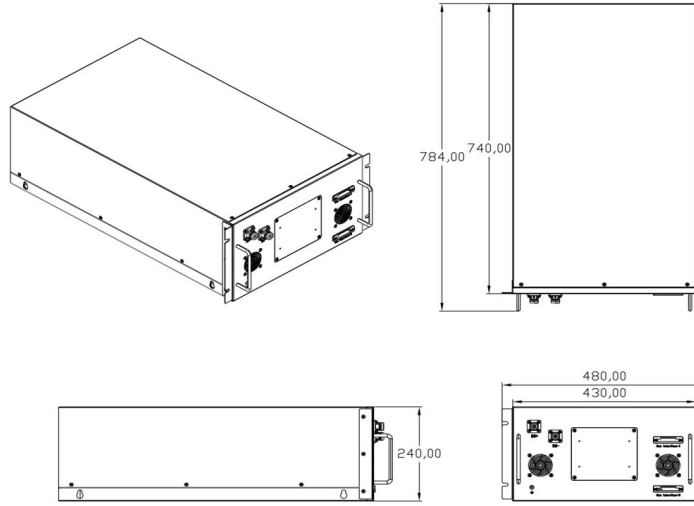

Figure Dimension of battery pack

- **Technical parameters of battery pack:**

Unit	Model/Description	HZ-PACK-15
	Cell type	LFP280Ah
	Maximum charge rate	0.5C
	Rated charge-discharge rate	0.5C
	Maximum discharge rate	0.5C
	Cell combination method	1P16S
	Nominal capacity	280Ah
	Nominal energy	14.336kWh
	Nominal voltage	51.2V
	Operating voltage range	43.2-57.6V
	Operating temperature range	
		Charging: 0°C–55°C

Table Technical parameters of battery pack

- High-voltage cluster control box

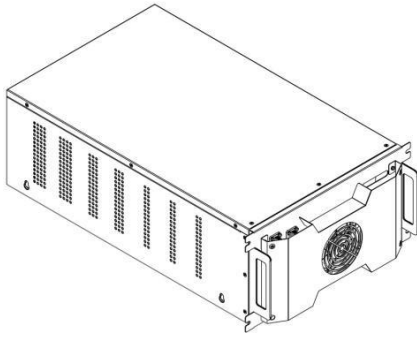
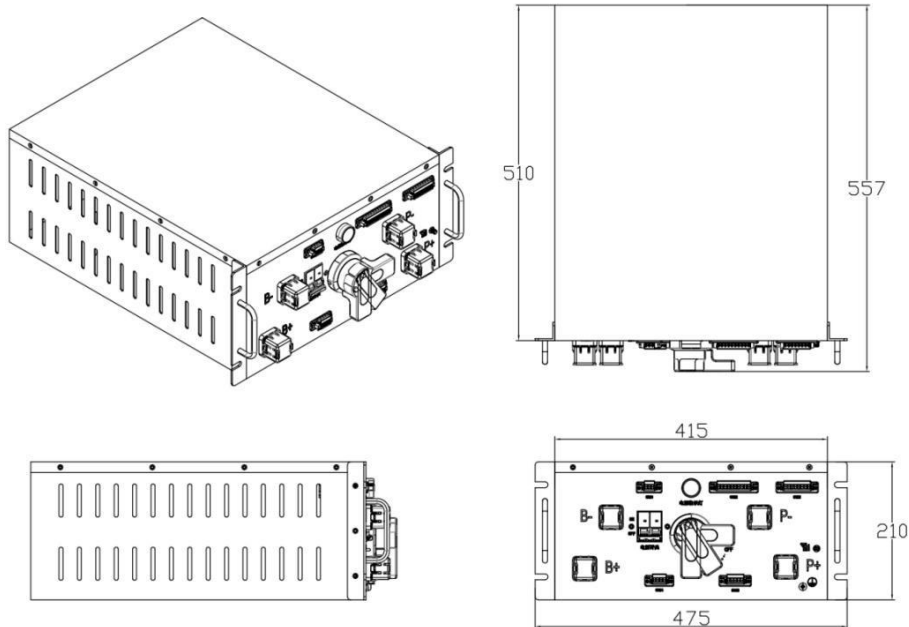

Figure Dimension of high-voltage cluster control box

- Control panel

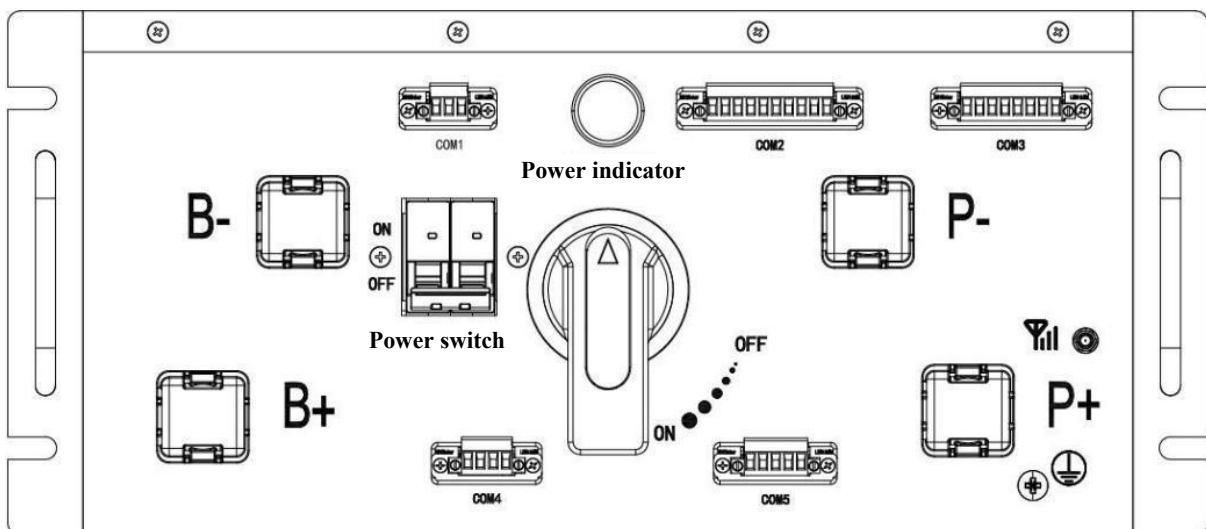

Figure Panel of high-voltage cluster control box

Power input/output interface definition:

Interface Definition	Function Description	Remark
B+	Battery cluster input positive terminal	Connect to the battery cluster positive terminal, with the interface using a M8 bolt
B-	Battery cluster input	Connect to the battery cluster negative terminal, with

	negative terminal	the interface using a M8 bolt
P+	PCS input positive terminal	Connect to the PCS positive terminal, with the interface using a M8 bolt
P-	PCS input negative terminal	Connect to the PCS negative terminal, with the interface using a M8 bolt

Table: Definition of power interface for high-voltage cluster control box

## Definition of communication interface:

No.	I/O	COM Port	Definition	Function Description
1	I	COM1(3P)	AC220V-N	N
2	/		/	/
3	I		AC220V-L	L
1	I/O	COM2(10P)	CAN1R	Terminal resistor
2	I/O		CAN1H	Isolated CAN (Connect to PCS or external device)
3	I/O		CAN1L	
4	I/O		CAN1G	
5	I/O		RS485-A1	
6	I/O		RS485-B1	
7	I/O		RS485-G1	
8	I/O		RS485-A0	Non-isolated 485 (Connect to display screen or external device)
9	I/O		RS485-B0	
10	I/O		RS485-G0	
1	O	COM3(8P)	GND	Switching value detection, effective short circuit
2	O		SWITCH_IN	
3	/		SW2_IN	Dry contact 2 (0.1 A)
4	I/O		SW2_OUT	
5	I/O		SW1_IN	Dry contact 1 (0.1 A)
6	/		SW1_OUT	
7	O		24V+_OUT	Output 24 V+ (Rated 75 W)
8	O		24V-_OUT	Output 24 V- (Rated 75 W)
1	I/O	COM4(4P)	DEBUG_CANH	Debug CANH
2	I/O		DEBUG_CANL	Debug CANL
3	I		24V+_IN	Input 24 V+
4	I		24V-_IN	Input 24 V-
1	I/O	COM5(5P)	SPI-H	Intranet daisy chain communication H
2	I/O		SPI-L	Intranet daisy chain communication L
3	/		/	/
4	O		FAN+	Fan power output 24 V+

5	O		FAN-	Fan power output 24 V-
---	---	--	------	------------------------

Table: Definition of communication interface for high-voltage cluster control box

### 3.6.3 Energy Storage Inverter

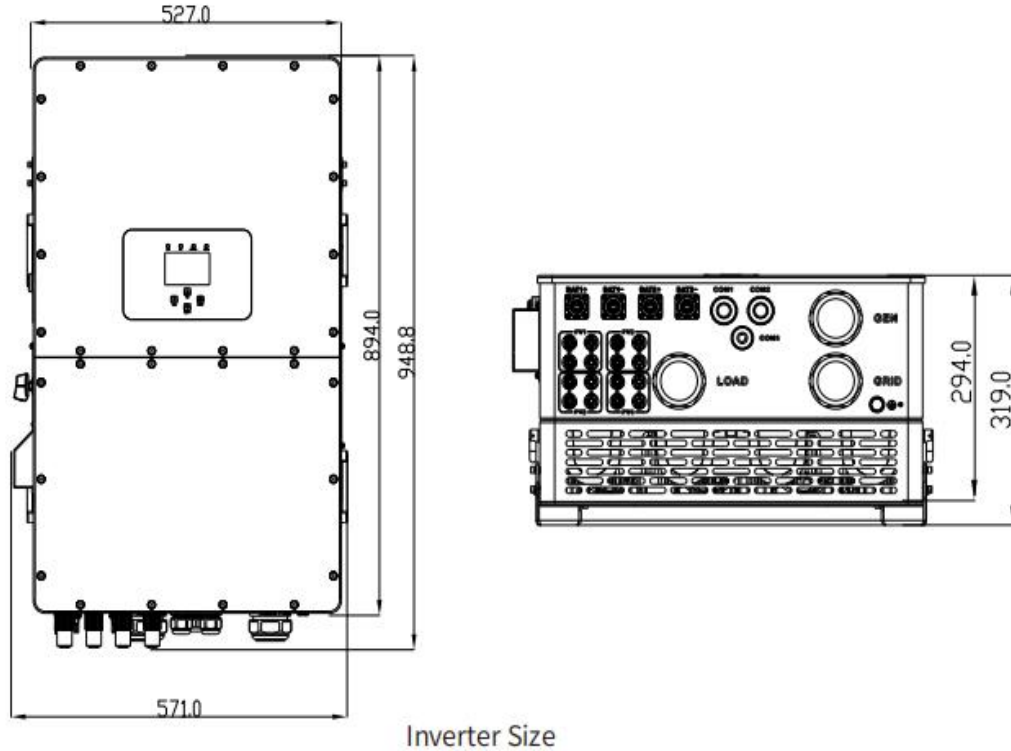

Figure Dimensions of the Converter

Inverter datasheet:

Model NO.	SUN-30K-SG01HP3-EU-BM3 (Optional)
Battery	Lithium battery
Battery Type	160-800
Battery voltage range (V)	50+50
Maximum charging current (A)	50+50
Maximum discharge current	2
Battery input number	Adaptive BMS system
Lithium battery charging management system	
DC input parameters	
Maximum DC input power(W)	39000
Maximum DC input voltage (V)	1000
Starting voltage (V)	180
MPPT voltage range (V)	150-850
Full load MPPT voltage range	360-850

(V)	
Rated DC input voltage (V)	600
Maximum DC input current (A)	36+36+36
Maximum DC short-circuit current (A)	55+55+55
MPPT	3
MPPT strings	2+2+2
<b>AC output parameters</b>	
Rated AC output active power (W)	30000
Maximum AC output active power (W)	33000
AC rated output current (A)	45.5/43.5
Maximum AC output current (A)	50/47.9
Maximum three-phase unbalanced output current (A)	60
Grid bypass current (A)	200
Peak Power (Off Grid)	1.5 times rated power, 10 seconds
Power Factor	0.8 Leading ~ 0.8 Lagging
AC output frequency and voltage	50/60Hz; 3L/N/PE 220/380, 230/400Vac
Grid type	Three-phase
Current harmonic distortion (at rated power)	THD<3% (linear load<1.5%)
Grid DC component	<0.5%In
<b>efficiency</b>	
Maximum efficiency	97.60%
European Weighted Efficiency	97.00%
MPPT efficiency	99.90%
<b>Protect</b>	
integrated	Island protection, DC reverse polarity protection, insulation impedance detection, surge protection, leakage current monitoring protection, output overcurrent protection, output short circuit protection, output overvoltage protection, arc fault circuit breaker (AFCI optional)
<b>Basic parameters</b>	
Certification and licensing	CQC
Operating temperature range (°C)	-40~60°C, >45°C Derating
Cooling method	-40~60°C, >45°C Derating
Noise Index (dB)	Intelligent air cooling
BMS communication port	≤65 dB
weight (kg)	RS485; CAN
Dimensions (HxWxD mm)	80
Protection level	527 x 894 x 294 (Connectors and brackets not included)
Installation	IP65

### Inverter Parameters

- **Thermal management system**
- **Battery pack fan**

The battery box cooling fans are controlled individually for each battery cluster, with the battery management main control unit managing the start and stop of the fans for each cluster. The BMS can control the fan operation based on the collected cell temperatures. By default, when the BMS detects that the temperature of any cell exceeds 28°C, it activates the fans for the corresponding battery cluster. Conversely, the fans will be turned off when the temperature of the entire cluster falls below 25°C.

Fan parameters:

Item	Remark
Rated Voltage	DC24V
Working voltage	DC 21.6V-26.4V
Start-up voltage	≤ DC 12V(ON/OFF)
Running current	110mA±10%
Noise	28.0dB

Table Fan parameters of battery pack

Control strategy for battery box fan:

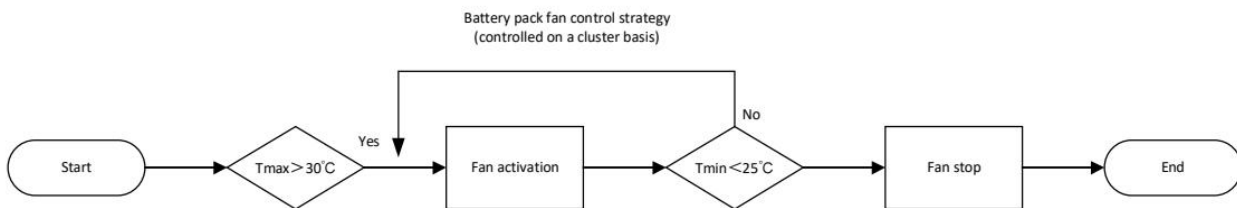

Table Battery pack fan control logic

- **Industrial temperature control air conditioning**

The industrial air conditioning for energy storage is an industrial air conditioning unit specifically designed for energy storage system. It features an integrated structure and high airflow design, providing a safe, reliable, and energy-efficient precision temperature control solution. The air conditioner offers both cooling and heating functions to meet various environmental application needs.

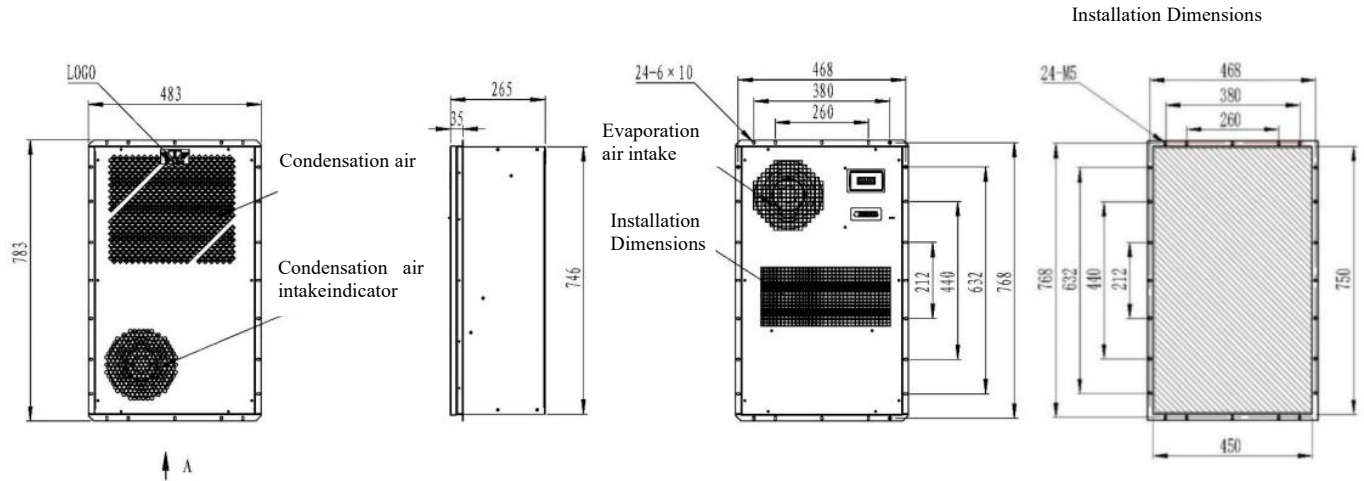

Figure Dimension of industrial air conditioning

## Air conditioner parameters

Item	Remark
Power supply	AC 220V 50Hz
Rated power	1.2kW
Rated current	5.6A
Rated cooling capacity	2kW
Heating power	1kW
Air flow of internal circulation	950m <sup>3</sup> /h
Operating ambient temperature	-40~55°C
Humidity control	Yes
Refrigerant	R134a
Noise	70dB
Installation method	Wall-mounted type
Protection level	IP55
External dimension	483×783×265mm
Net weight	40kg

Table Industrial air conditioning parameters

Air conditioner control strategy:

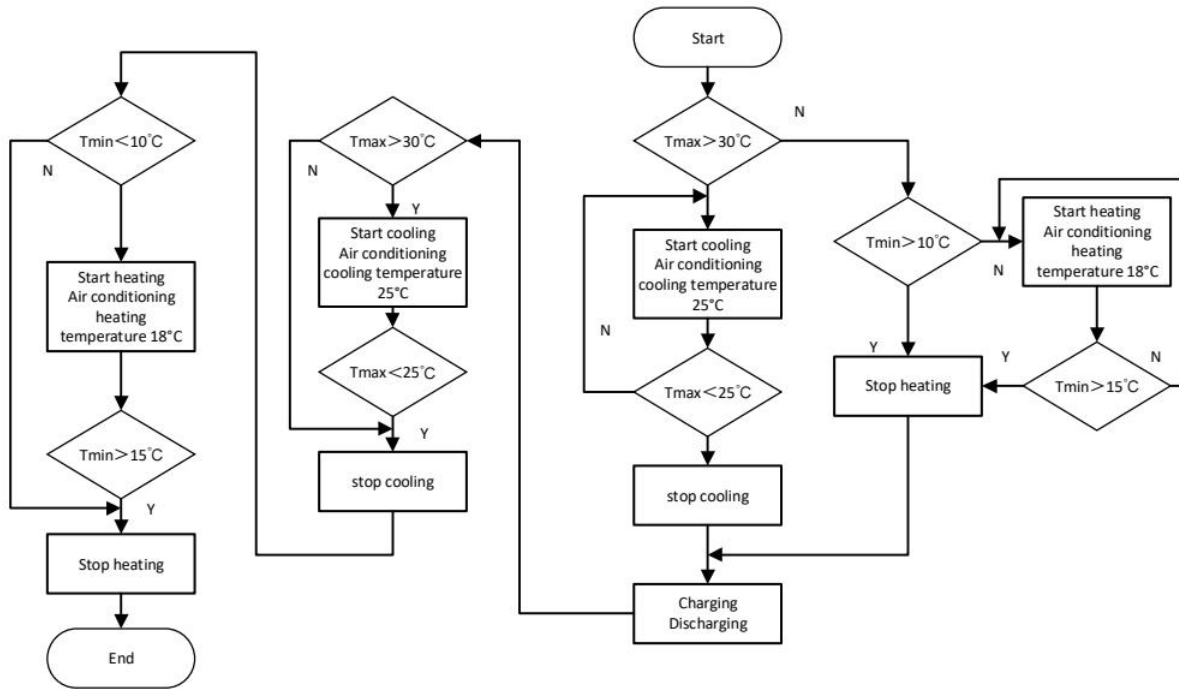

Figure Control logic flow of industrial air conditioning

- **Fire protection system**
- **Fire protection layout**

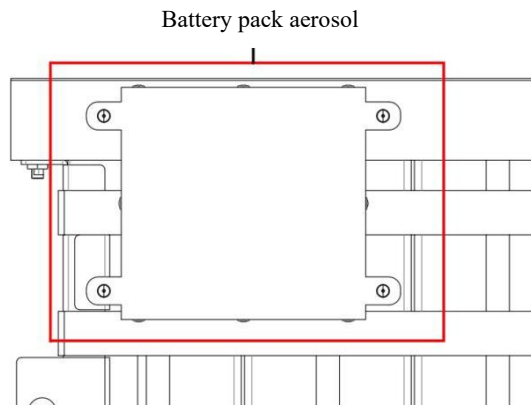

Figure Diagram of battery pack fire protection

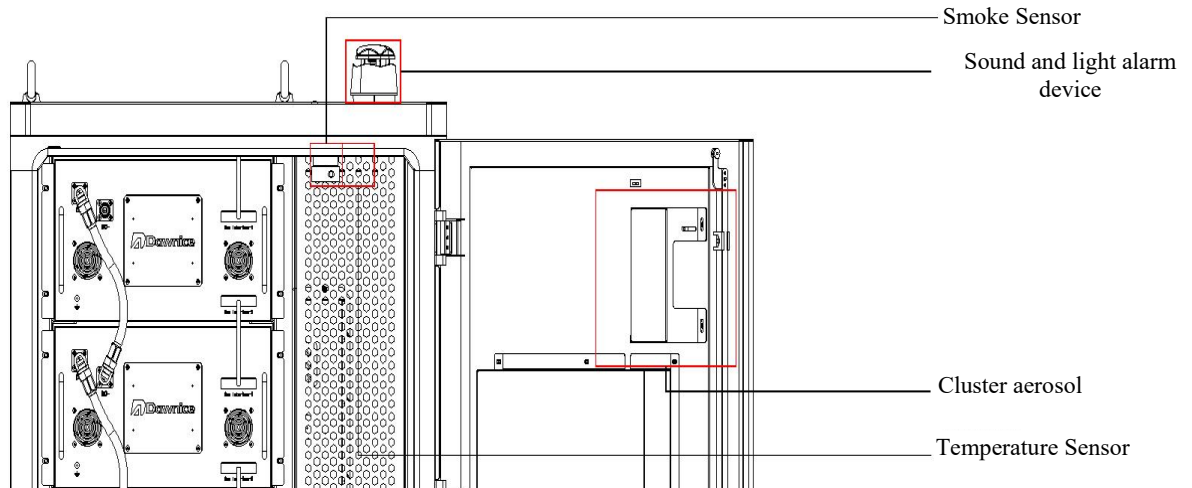

Figure Battery cabinet fire protection system installation diagram

- Working principle of fire protection equipment**

Only the smoke sensor is triggered, the sound and light alarm starts working, and the cluster aerosol device does not start.

- Only the temperature sensor is triggered, the sound and light alarm starts working, and the cluster aerosol device does not start.

- The smoke sensor is triggered, the temperature sensor is triggered, the sound and light alarm starts working, the cluster aerosol is triggered to spray, and the EMS issues the air conditioner shutdown command and the PCS shutdown command.

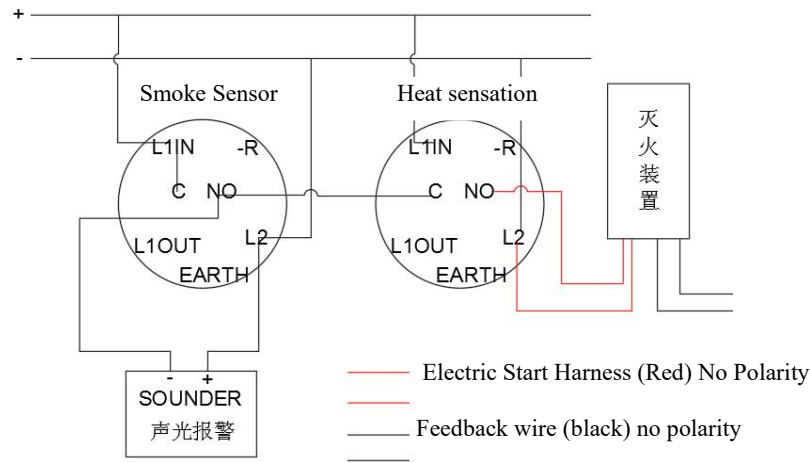

Figure Working principle of fire protection system

- **Fire extinguishing mechanism**

The suppression effect of thermal aerosols on fires is mainly reflected in the following aspects:

Fire extinguishing agents generally operate through mechanisms such as isolation, suffocation, cooling, or chemical suppression, with different agents utilizing various mechanisms. Thermal aerosols primarily work through two mechanisms: cooling through endothermic decomposition and chemical suppression in both the gas and solid phases, which act synergistically. Additionally, the gaseous components in the byproducts of aerosol fire extinguishing agent also play a supportive role.

- **Cooling and extinguishing effect of endothermic decomposition**

The cooling effect of thermal aerosol fire extinguishing agents primarily relies on the endothermic decomposition of metal oxides and carbonates. Since the heat released by a fire in a short period is limited, if the solid particles in the aerosol can absorb a portion of this heat quickly, the flame temperature will decrease. This reduces the heat radiated to the combustion surface and the energy used to break down vaporized combustible molecules into free radicals, thereby suppressing the combustion reaction to some extent.

- **Gaseous chemical suppression**

Under heat, the vaporized metal ions from the decomposition of thermal aerosol fire extinguishing agents, such as Sr, K, Mg, or cations that have lost electrons, exist in the form of vapor. These ions participate in multiple chain reactions with the active radicals in the combustion process, such as  $H\bullet$ ,  $\bullet OH$ , and  $O\bullet$ . For example, considering Sr:

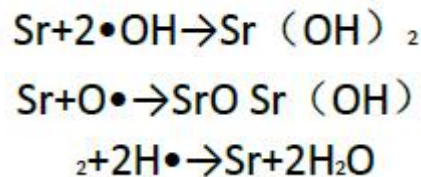

As this process continues, the active radicals in the combustion are significantly consumed, resulting in a continuous decrease in their concentration, which suppresses the combustion.

### 3) Solidoid chemical suppression

The solid particles in thermal aerosol fire extinguishing agents can adsorb intermediate such as  $\bullet OH$ ,  $H\bullet$ , and  $O\bullet$  from chain reactions. These particles then catalyze the recombination of these members into stable molecules, effectively interrupting the branching chain reactions of the combustion process. For example, considering K:

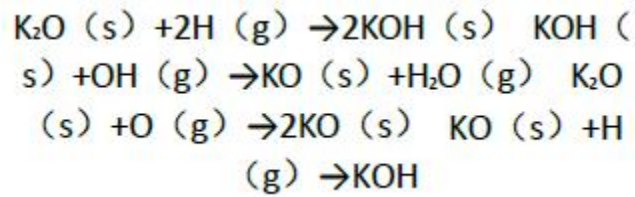

In the described extinguishing mechanisms, various methods interact and work synergistically. However, the gas transport and the endothermic cooling effects of metal oxides or carbonates serve primarily as auxiliary effects. The main extinguishing effect relies on the chemical suppression in both the gas and solid phases.

- **Thermal aerosol fire extinguishing device**

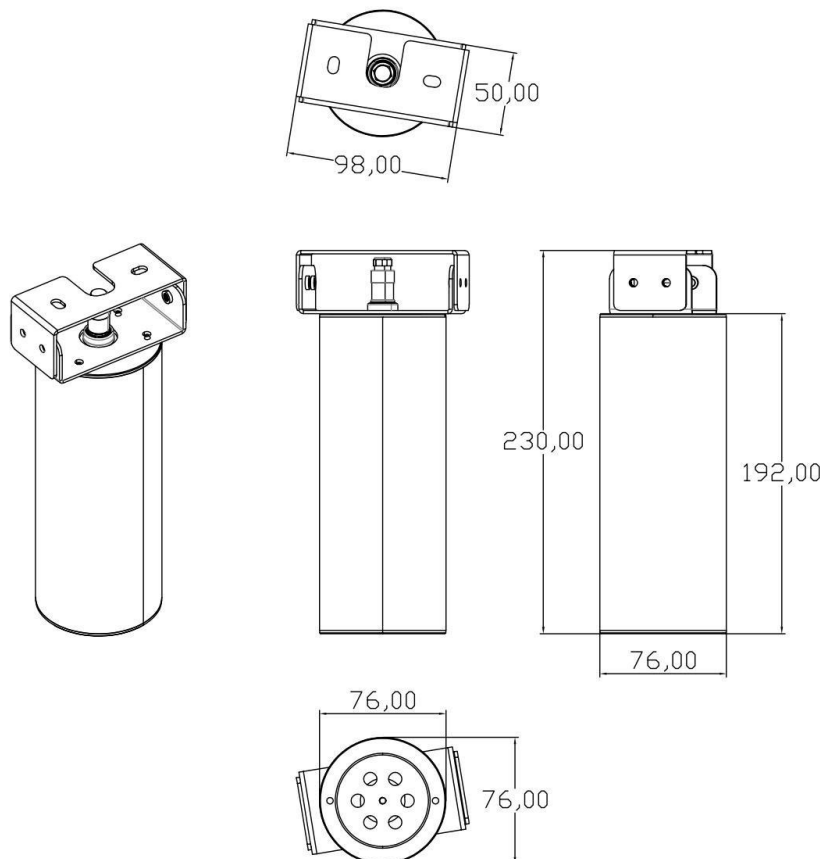

Figure Diagram of thermal aerosol

## Technical Parameters

JAD300-U01	Content	Technical Parameters
	Starting mode	Electrical starting
	Feedback signal	Passive switch signal
	Protection space	5 m <sup>3</sup>
	Validity	15 years
	Dimension	Φ76×192 mm
	Operating environment	-40°C--+54°C
	Executive standard	UL2775/EN15276/AS4487/XF499.1

Table Technical parameters of thermal aerosol

- Temperature sensor**

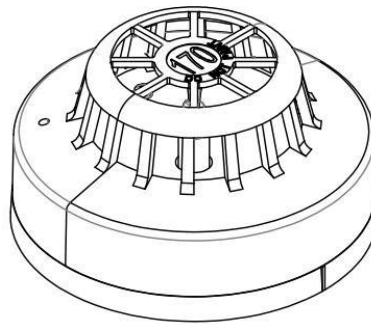

Figure Diagram of temperature sensor

## Technical Parameters

958CHL1000	Content	Technical Parameters
	Output voltage	9 to 33V
	Quiescent current	24V: 55μA
	Alarm voltage	6 V to 28 V
	Alarm voltage	24V: 52mA
	Storage temperature	-30°C to +80°C
	Operating temperature	CS/CR: -20°C to +80°C
	Ambient humidity	0%–95% RH without condensation
	IP level	IP54
	Executive standard	CPR, LPCB, VdS, VNIPO, SBSC, FG, BOMBA
	Dimension	Diameter 100 mm × height 42 mm (with base 50 mm)

Table Technical parameters of temperature sensor

- Smoke sensor**

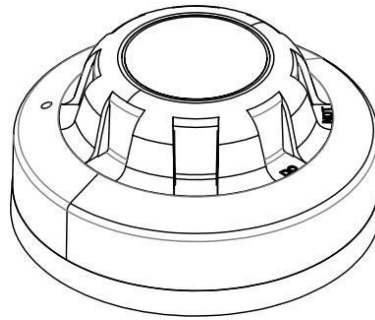

Figure Diagram of smoke sensor

**Technical Parameters**

958CHL1000	Content	Technical Parameters
	Output voltage	9 to 33V
	Quiescent current	30 - 50 $\mu$ A at 24 V
	Alarm voltage	6 V to 28 V
	Alarm current	52 mA at 24 V
	Alarm LED lamp current	4 mA
	Operating temperature	-20°C-+60°C
	Ambient humidity	0%–95% RH without condensation
	IP level	IP23D
	Executive standard	EN 54-7, LPCB, VdS, DIBt, BOSEC, FG, CPR and SBSC
	Dimension	Diameter 100 mm $\times$ height 42 mm (with base 50 mm)

Table Technical parameters of smoke sensor

- Sound-light alarm device**

Figure Diagram of sound-light alarm device

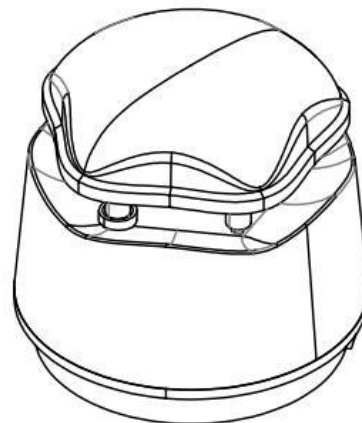

## Technical Parameters

958CHL1000	Content	Technical Parameters
	Working voltage	9-30V DC
	IP level	Type A/IP 45 Std Base
	Operating temperature	-20°C+70°C
	Decibel	High, Medium (-10 d B(A)) Low (-20 d B(A))
	Executive standard	EN 54-3

Table Technical parameters of sound-light alarm device

- Gas detector

Figure Diagram of gas detector

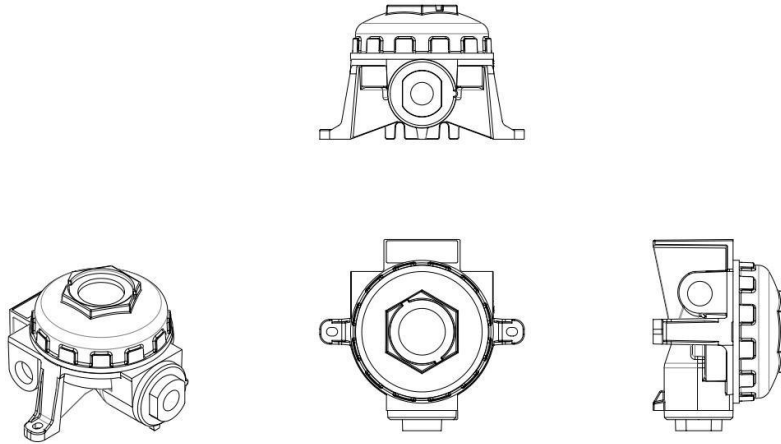

## Technical Parameters

	Content	Technical Parameters
	Protection level	IP66
	Sensor type	Electrochemical/catalytic combustion/PID/infrared
	Operating temperature	-40-60°C
	Storage temperature	-20-40°C
	Ambient humidity	0%–95% RH without condensation
	Accuracy	2%FSD (Typ.)
	Zero drift	2%FSD/month (Typ.)
	Repeatability	≤2%
	Working voltage	10-30VDC
	Certification	GB15322.1-2003,GB12358-2008,GB3836.2-2003

Table Technical parameters of gas detector

- Working principle
- Single machine topology structure

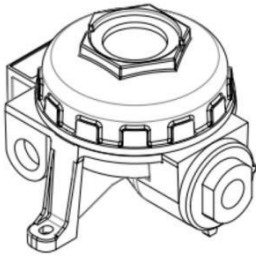
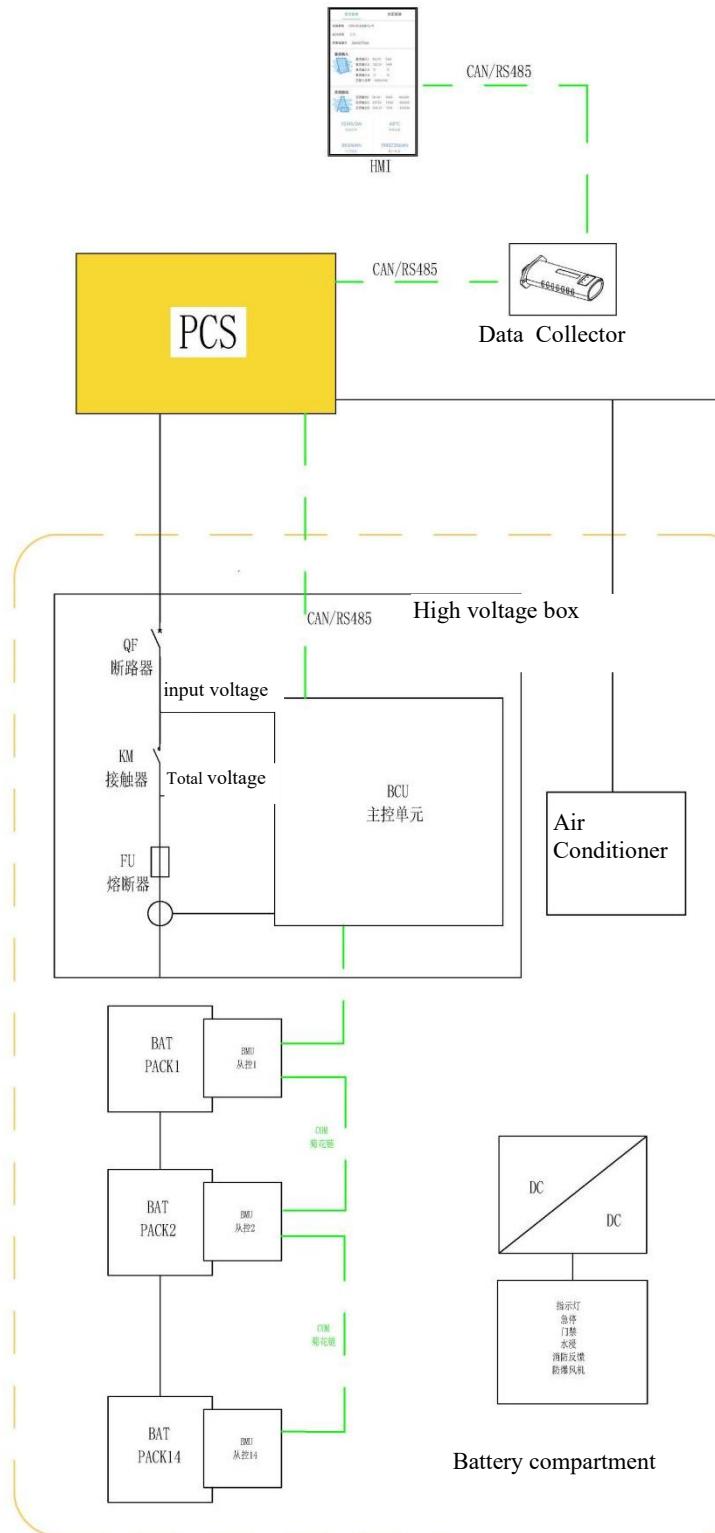

Figure Battery cabinet topology

- Typical application scenario

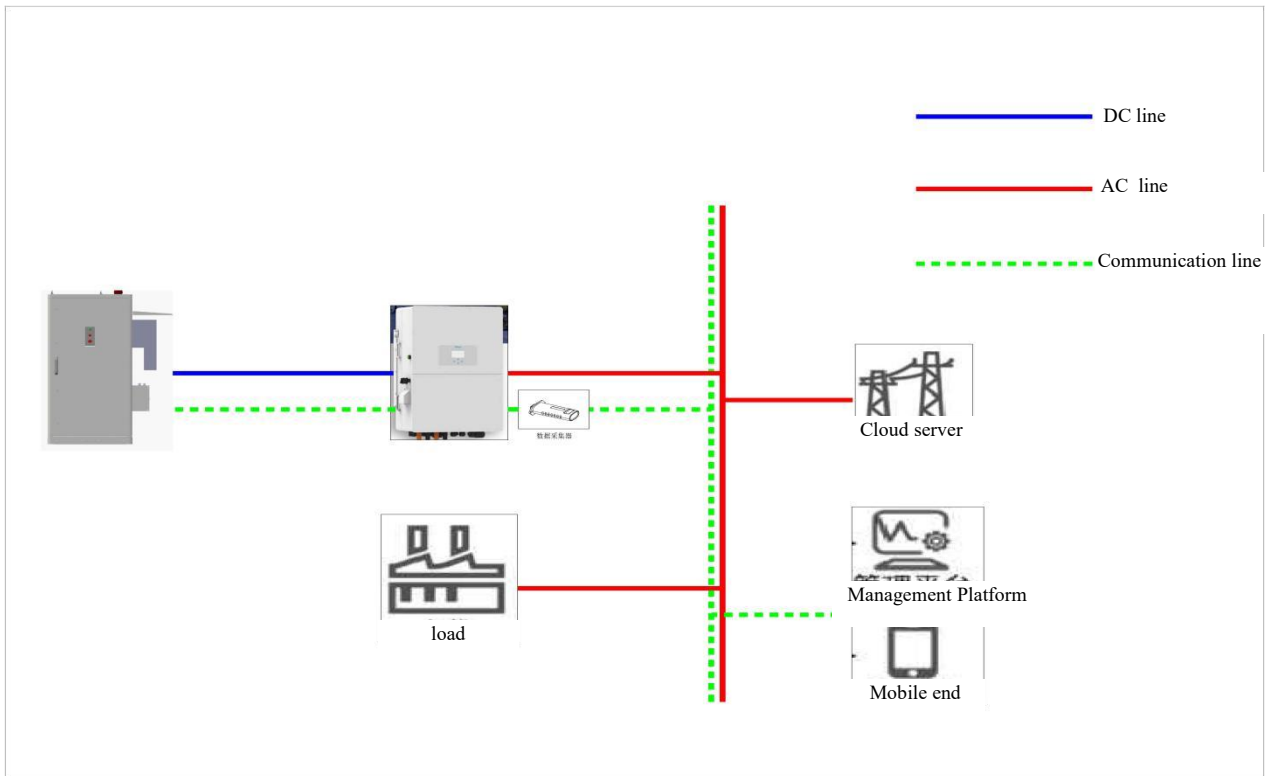

Figure Typical application scenario

※: This product is only used as a complete energy storage system on the DC side of the system (i.e. the battery part in the typical application scenario shown in the figure), and PCS, EMS and other equipment need to be selected for use.

## ● Transportation requirement

### • Moving requirement



#### Warning

During the moving process, comprehensive safety measures must be implemented. When moving items, handle them gently, avoid dragging or throwing them on rough surfaces.

- When moving heavy objects, be prepared to support the weight properly to avoid injury from being crushed or strained.
- When two or more people are moving heavy objects together, one person should be in charge of directing the process. Everyone should lift or lower the equipment simultaneously and in unison.
- When moving equipment manually, you should wear protective gloves and safety shoes, among other safety gear, to prevent injuries.
- When manually moving equipment, approach the object, squat down, and use the strength of your straightened legs rather than your back to lift it. Lift slowly and steadily, avoiding sudden jerks or twisting of the torso.
- When moving or lifting equipment, hold onto the equipment handles or support the bottom edge, rather than gripping handles attached to installed modules.
- Avoid lifting heavy objects quickly above waist height. Place the object on a workbench or suitable surface at waist level first, adjust your grip, and then lift it.
- When moving heavy objects, apply force evenly and steadily. Move at a consistent, slow speed and position the object carefully to avoid impacts or drops that could scratch the equipment surface or damage components and cables.
- When moving heavy objects, be especially cautious around workbenches, ramps, stairs, and slippery areas. Ensure that doorways are wide enough to accommodate the equipment when moving through them to prevent injury or damage.
- When transporting heavy objects, move your feet rather than twisting your waist. If you need to lift and move the object simultaneously, first point your toes in the direction you intend to move, then proceed with the lift.
- When using a forklift, ensure the forks are positioned in the center to prevent tipping. Before moving, secure the equipment with straps, and assign a person to oversee the operation.
- The placement angle should meet the requirements: with packaging, the tilt angle  $\alpha$  should be  $\leq 15^\circ$ , and after removing the packaging, it should be  $\leq 10^\circ$ .

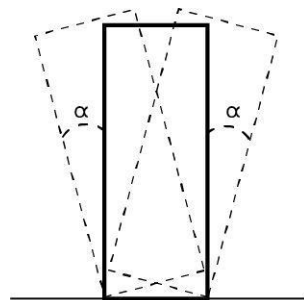

- During the moving and transportation of air conditioners, keep the unit in an upright position at all times. Do not place the air conditioner flat or on its side.

### • Transportation requirement

- Rough handling during loading and unloading is prohibited, as it may cause battery short circuits, damage (such as leakage or rupture), fire, or explosion.

- During moving, ensure that the battery is transported according to its specified orientation. Do not invert, tilt, drop, expose to mechanical impacts, or subject to rain, snow, or immersion in water.
- Batteries must be transported separately. For cabinets equipped with batteries, transportation with the batteries installed is prohibited. If the cabinet needs to be transported or moved, the batteries must be removed first.
- The battery is certified according to UN38.3 (UN38.3: Section 38.3 of the sixth Revised Edition of the Recommendations on the Transport of Dangerous Goods: Manual of Tests and Criteria) and is classified as a Class 9 hazardous material.
- The transport service provider must have qualifications for handling hazardous materials. The use of open-top vehicles is strictly prohibited.
- The battery can be shipped directly to the site, provided it meets the transportation requirements for vehicles, ships, and other modes of transport.
- The international regulations for the transport of hazardous materials should be complied with, and the regulatory requirements of the origin country, transit countries, and destination country authorities should be met.
- Sea transport or well-maintained highways should be used for shipping; rail and air transport are not supported. During transport, minimize bumps and tilting as much as possible.
- For sea transport, adhere to the requirements of the International Maritime Dangerous Goods Code.
- Before transport, the battery packaging must be checked for completeness and integrity. Ensure there are no signs of odor, leakage, smoke, or fire; otherwise, transport is prohibited.
- The transport packaging must be sturdy. Handle with care during loading, unloading, and transit, and implement moisture protection measures.

## ● Storage requirements



### Note

Due to the characteristics of lithium batteries, storage must adhere to specific battery storage requirements. Failure to do so may result in permanent damage or performance degradation.

- Battery packs should not be stored for extended periods. Long-term storage of lithium batteries can lead to capacity loss, with an irreversible capacity loss of 3% to 10% typically occurring after 12 months at recommended storage temperatures.

1. The battery should be stored in a clean, dry place, and should be protected from dust and moisture. Avoid exposure to rain or standing water.

2. The environment must be free from corrosive or flammable gases.

3. The battery should not be stored tilted or inverted.

4. For equipment other than battery packs that has been stored for two years or more, it must be inspected and tested by a professional before use.

- **Energy storage system storage (excluding battery pack)**

- Avoid removing the packing during long-term storage.

- Avoid stacking storage.

- Store (long-term or temporary) on a flat surface.

- Close the cabinet door tightly.

- Storage environment temperature:  $-40^{\circ}\text{C}$ – $+60^{\circ}\text{C}$ , relative humidity: 5% RH–90% RH.

- **Battery pack storage**

- Batteries should be stored indoors, away from direct sunlight and rain, in a dry and well-ventilated area. The surroundings should be clean, free from excessive infrared or other radiation, organic solvents, corrosive gases, and conductive metallic dust. Keep them away from heat and ignition sources.

- If a battery shows signs of fault (such as carbonization, leakage, swelling, or water ingress), it must be promptly transferred to a hazardous materials storage area, kept at least 3 m away from flammable materials, and disposed of as soon as possible.

- When storing batteries, place them according to the packaging labels. Do not store them upside down, on their side, or tilted. Ensure stacking complies with the requirements specified on the outer packaging.

- Batteries should be stored separately from other equipment and should be avoided stacking too high. Ensure that the site is equipped with appropriate fire safety measures, such as fire sand and extinguishers.

- After discharging, batteries may experience static power consumption of internal modules and self-discharge, which could lead to damage from over-discharge. Avoid storing batteries in a low-charge state and promptly recharge them. If a battery experiences permanent fault due to lack of recharging beyond the recommended period, the Company will not provide warranty services. Scenarios triggering low-charge storage include but are not limited to:

- Battery power cables or signal lines are not connected

- The battery cannot enter charging mode due to a system fault after discharging in an energy storage system

- The battery cannot enter charging mode due to improper configuration of the energy storage system

- The battery cannot enter charging mode due to prolonged loss of AC power

- The battery cannot enter charging mode due to the control system, PCS (Power Conversion System), or main circuit components not being properly closed or engaged

## • **Storage environment requirements**

- Environmental temperature:  $-30^{\circ}\text{C}$ – $+50^{\circ}\text{C}$  (excluding battery pack)
- Environmental temperature:  $0^{\circ}\text{C}$ – $30^{\circ}\text{C}$  (battery pack); It is recommended to store the battery pack in a constant temperature environment of  $25^{\circ}\text{C}$ . Long term storage may affect the performance and service life of the battery.
- Relative humidity: 5% RH–90% RH (recommended around 45% RH).
- Dry, ventilated, and clean.
- Avoid contact with corrosive organic solvents, gases, and other substances.
- Avoid direct sunlight.
- The distance from the heat source should not be less than two meters.
- When storing, it is necessary to disconnect from the external connection. If there is an indicator on the battery pack panel, the indicator should be in the off state.
- Report any overdue storage promptly.
- When shipping batteries, follow the first-in, first-out principle.
- Move batteries gently during transport, and avoid damaging them.

## ● Installation site requirement

### • Location requirement

- This system is only applicable to outdoor scenes.
- The installation environment horizontal surface should be elevated above the area historical highest water level and at least 300 mm above the ground. The installation site must not be in a low-lying area.
- The installation site and a 3-meter surrounding area of the energy storage system or energy storage station should be free of vegetation and flammable plants to prevent fires caused by wildfires during high summer temperatures.
- The safety distance between the energy storage system and buildings should comply with local fire safety regulations or standards.
- The safety distances for the energy storage system are as follows: at least 12 m from Class A production buildings, at least 10 m from Class B production buildings, at least 10 m from Class C, D, and E production buildings with a fire resistance rating of Grade I or II, at least 12 m from Class C, D, and E production buildings with a fire resistance rating of Grade III, and at least 12 m from residential buildings. If the exterior walls of adjacent buildings are non-combustible and have no doors, windows, or exposed combustible eaves, the fire safety distance can be reduced by 25% from the previously specified distances.
- If the specified safety distances cannot be met, a fire wall must be installed between the battery equipment room, energy storage room, or energy storage installation area and Class C, D, and E buildings. The fire wall should have a fire resistance rating of at least 3 hours and extend 1 m beyond the outer contours of the energy storage system in terms of length and height. Additionally, the fire wall design should consider space requirements for equipment transportation, installation, and maintenance.
- The energy storage system or energy storage station must be situated in an environment free from explosion or fire risk.
- The site should have convenient transportation access and reliable fire suppression system equipment.

### **Description 1**

- During the installation, commissioning, and operation phases of the energy storage system, the fire safety principle should be prioritized. At least two gas fire extinguishers, such as those using halon, perfluorohexane, or carbon dioxide, should be placed near each unit.
- Please reserve a water fire extinguishing system interface for the energy storage system site.
- Ensure the site meets the immediate space requirements and provides additional space for future expansion based on the full lifecycle needs.
- Choose a place with good ventilation
- The energy storage system should not be installed in areas prone to salt damage or pollution, as it will suffer from corrosion. It is suitable for use in the following or better environments:
  - The energy storage system is suitable for outdoor environments more than 2,000 m from the coast. It is not recommended for use within 500 m–2,000 m of the coast (if needed, confirm with the distributor or our engineers). The system should not be used within 500 m of the coast.
  - 1,500 m–3,000 m away from heavy pollution sources such as smelters, coal mines, and thermal power plants
  - 1,000 m–2,000 m away from moderate pollution sources such as chemical, rubber, and electroplating
  - 500 m–1,000 m away from light pollution sources such as food, leather, heating boilers, slaughterhouses, centralized garbage dumps, and sewage treatment plants

### **Description 2**

If the safety distance at the selected site does not meet relevant national standards, it is advisable to choose a new location. The site should avoid scenarios not recommended by industry standards and regulations,

including but not limited to the following areas, regions, and locations:

- Areas with strong vibration, intense noise sources, and significant electromagnetic interference.
- Places with dust, oil smoke, harmful gases, or corrosive gases.
- Places where corrosive, flammable, or explosive materials are produced or stored.
- Places with existing underground facilities.
- Areas with poor geological conditions, such as rubber soil, soft soil layers, or surfaces prone to water accumulation and subsidence.
- Areas beneath water reservoirs, water landscapes, or water intake rooms.

### **Description 3**

- If placement in a potentially water-accumulating area is unavoidable, install barriers, drainage facilities, or elevate the ground.
- Cable trenches should not be used as drainage pathways. Penetrations for cables through walls or floors must be fire-stopped.
- Areas with seismic fault lines or seismic zones with a risk level higher than magnitude 9.
- Areas prone to direct hazards such as mudslides, landslides, quicksand, or sinkholes.
- Within the boundaries of mining subsidence (displacement) zones.
- Within the blast danger zones.
- Areas that could be submerged if a dam or levee were to fail.
- Important sanitary protection zones for water supply sources.
- Historical and cultural heritage protection zones.
- Crowded places, high-rise buildings, and underground structures.
- Intersections of arterial street and heavily trafficked areas.

### **Site selection for flood and drainage control:**

- For large-scale electrochemical energy storage system (with a power rating of  $\geq 100$  MW), the site design elevation should be higher than the 1% flood level or the highest historical flood level.
- For medium and small-scale electrochemical energy storage system (with a power rating of  $< 100$  MW), the site design elevation should be higher than the 2% flood level or the highest historical flood level.
- If the site design elevation cannot meet the above requirements, choose an alternative site or implement various flood and drainage measures based on different conditions.
- For energy storage stations along rivers, lakes, or coastal areas affected by wind and waves, flood protection facilities should be designed to accommodate a 2% wave height plus an additional 0.5 m for safety.
- When there is significant runoff entering or crossing the site perimeter, it is advisable to install ditches or drainage (cut-off) channels to manage surface water drainage systematically.

### **Fence against illegal entry:**

It is recommended to use solid walls or fences for isolation and protection around the energy storage area. The fence should have a lockable gate, and its height should be greater than 2.2 m. Firewalls may replace part or all of the fencing, depending on the design considerations.

- **Foundation requirements**

### **Foundation design requirements:**

- The energy storage system must be installed on a concrete or other non-combustible surface. Ensure that the installation plane is level, stable, and even, with sufficient load-bearing capacity. Installation on surfaces with depressions or inclines is prohibited.

- The equipment foundation should be designed based on a load-bearing capacity of 2,750 kg per unit. If the foundation load-bearing capacity is insufficient, it must be reassessed.
- The bottom of the equipment foundation pit must be thoroughly compacted and levelled.
- After excavation of the equipment foundation, avoid water exposure and disturbance. If water exposure occurs, continue excavation and replace the disturbed material.
- The horizontal deviation between the equipment foundation and the equipment contact surface must not exceed 3 mm.
- The foundation must be higher than the local historical highest water level and at least 300 mm above the ground.
- Construct drainage facilities based on local geology and municipal drainage requirements to prevent water accumulation at the equipment foundation. The equipment foundation must meet the drainage requirements for the area's historical maximum rainfall, and the discharged water should be treated in accordance with local laws and regulations.
- When constructing the equipment foundation, consider the routing of energy storage system cables by reserving trenches or entry holes.
- The reserved holes in the equipment foundation and the entry holes at the bottom of the equipment should be properly sealed.
- Users must verify the foundation design parameters of the energy storage system based on the project's installation environment, geology, and seismic requirements.

### • **Forklift requirements**

- Do not move the energy storage system after the battery pack harness has been installed.
- If using a forklift for cabinet installation, the forklift load capacity must be  $\geq 3$  t.
- If using a forklift for battery pack installation and maintenance, the forklift load capacity must be  $\geq 1$  t.
- Recommended fork length: 1,300 mm–1,500 mm, width: 80 mm–160 mm, and thickness: 25 mm–80 mm.
- Forklift lifting height requirement: when the foundation height is  $\leq 0.3$  m, the lifting height should be  $\geq 2$  m; when the foundation height is greater than 0.3 m, the lifting height increases accordingly.

### • **Lifting requirements**

Personnel involved in lifting operations must receive relevant training and be certified as competent before they can perform the tasks.

- The lifting area must be marked with temporary warning signs or fenced off for isolation.
- The foundation for lifting operations must meet the load-bearing requirements for the crane.
- Before lifting, ensure that the crane and lifting ropes meet the load-bearing requirements.
- Before lifting, ensure that the lifting tools are securely fixed to fixed structures or walls that meet the load-bearing standards.
- During lifting operations, do not walk under the crane boom or the lifted load.
- During lifting operations, do not drag wire ropes or lifting equipment, and avoid using hard objects for impact.
- During lifting, ensure that the angle between the two cables does not exceed  $90^\circ$ .
- When installing or dismantling lifting equipment, avoid dragging it across the cabinet to prevent scratches.
- Do not perform lifting or moving operations after the battery pack has been installed in the energy storage system.

### **Lifting precautions:**

**Before lifting:**

- Crane lifting capacity  $\geq 3$  t, working radius  $\geq 2$  m. If the on-site working conditions do not meet requirements, consult a professional for assessment.
- Personnel involved in lifting operations must receive relevant training and be certified as competent before they can perform the tasks.
- Lifting tools must be inspected and complete before use.
- Ensure that lifting tools are securely fixed to load-bearing structures or walls.
- When using outdoors, it is recommended to perform lifting operations in clear, calm weather conditions.
- Confirm that the crane and steel cables meet the requirements before proceeding with the lift.
- The doors of the equipment have all been closed and locked.
- Ensure the safe and reliable connection of steel cables.
- It is recommended to use a left-to-right or right-to-left lifting sequence to ensure a smooth lifting operation.

**During lifting:**

- Unauthorized personnel must not enter the lifting area, and no one should stand under the crane boom.
- Ensure the crane is positioned correctly and avoid long-distance lifting.
- Maintain stability, ensuring that the diagonal tilt of the cabinet does not exceed  $5^\circ$ .
- Ensure that the angle between the two cables does not exceed  $90^\circ$ .
- Lift and place the equipment gently. Lower the cabinet slowly and steadily to avoid impacting the internal components.
- When the cabinet contacts the base, wait until the load on the base is evenly distributed before removing the lifting cables.
- Do not drag wire ropes or lifting equipment, and avoid equipment collisions.
- Only proceed with lifting subsequent cabinets after the initial cabinet has been securely fixed.

## ● Equipment installation

### • Preparation before installation

Prepare tools:

- The illustrated tools are for reference only, please refer to the actual product.
- Due to varying site conditions, this tool list may not cover all possible tools. Installers and users should prepare any additional tools based on the actual situation.





Mounting tools:

 Slotted insulated screwdriver	 Phillips insulated screwdriver	 Wire stripper	 Diagonal pliers
 Wire cutter	 Art knife	 Wrench	 Rubber hammer
 Electric hand drill	 Cable drilling tool	 Cutting machine	 Tape
 Levelling instrument	 Vernier caliper	 Steel ruler	 Brush
 Cable tie	 Multimeter	 Heat gun	 Dust collector
 Lifting cable	 Insulation ladder	 Forklift	 Crane

Diagram-Installation tool diagram

Personal protective tools:

 Insulating gloves	 Protective gloves	 Reflective vest	 Safety belt
--	--	---	--

 Insulated shoes	 Safety helmet	 Goggles	 Protective mask
--	--	---	--

Icon-Protective tool diagram

• **Product installation**

- Step 1: open the cabinet door and remove the items and accessories inside the cabinet
- Step 2: confirm that the moving parts inside the cabinet are securely fixed
- Step 3: close the cabinet door and lock it securely
- Step 4: remove the bottom baffle
- 

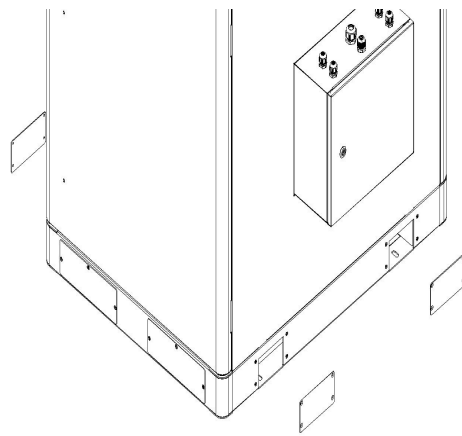
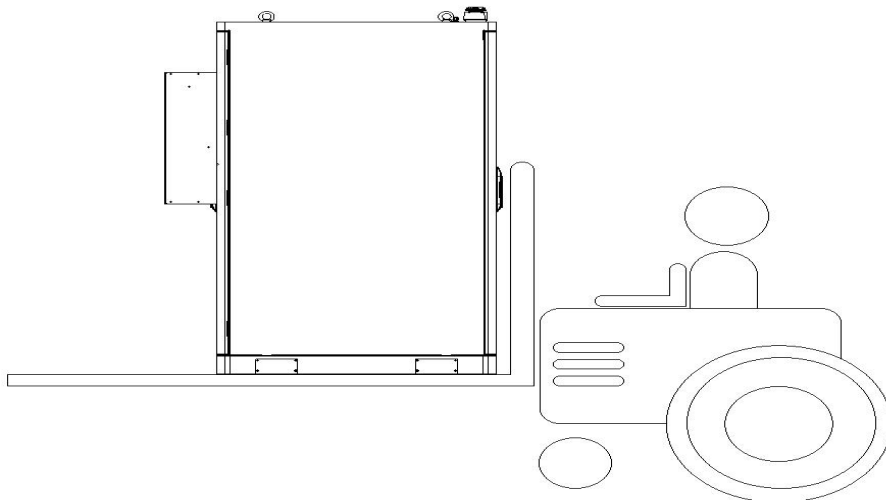

Figure-Diagram of disassembly and assembly of bottom baffle

- Step 5: use forklift ① (or hoist ②) to move the battery cabinet



Note ①: During forklift operations, only front and rear lifting are allowed. Lifting from the sides can cause the forklift to tip over due to a shift in the center of gravity, which may result in personnel injury and equipment damage.

Figure-Lifting diagram

Note <sup>®</sup>: During lifting operations, ensure that the angle between any two cables does not exceed 90°. Exceeding this angle may lead to lifting accidents, causing injury to personnel and damage to equipment.

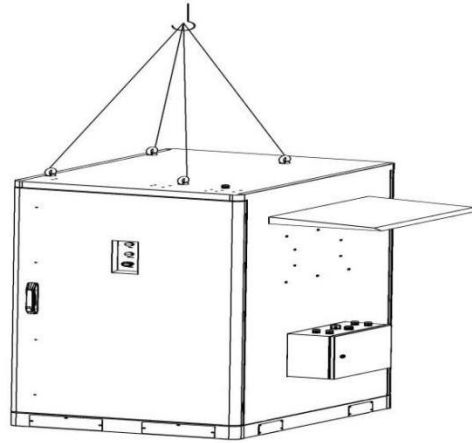

- Step 6: secure the energy storage battery cabinet with bolts

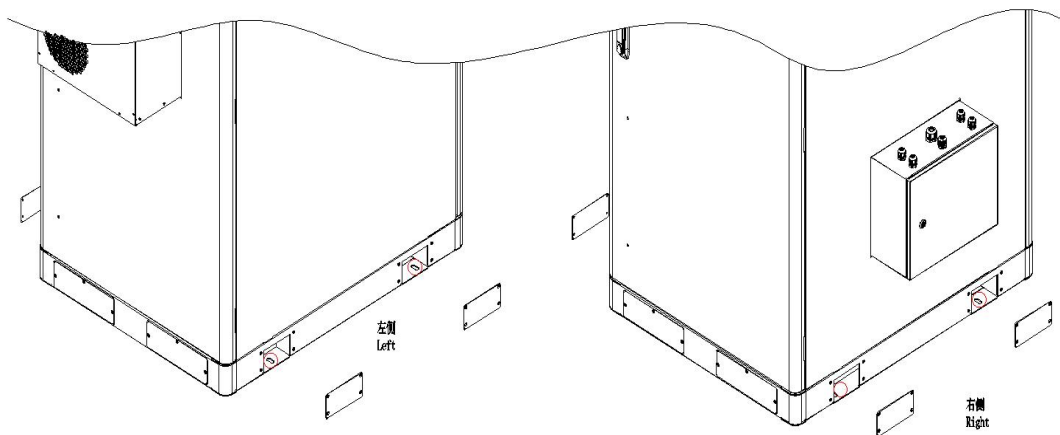

Figure-Fixing diagram

—End

## ● Cable installation

### • Prepare the cable

Before installing cables, check the following accessories:

Name	Type	Conductor Cross-section	Source
Battery pack cable	Prefabricated DC cable (with corrugated tube)	35mm <sup>2</sup>	System Configuration
Battery-cluster control box connection cable	Prefabricated DC cable (with corrugated tube)	35mm <sup>2</sup>	System Configuration
Cluster control box-converter connection line	Prefabricated DC cable (with corrugated tube)	35mm <sup>2</sup>	Pre-installed
Converter-AC Circuit Breaker	Prefabricated AC cable (with corrugated tube)	35mm <sup>2</sup>	Pre-installed
Slave communication cable	Prefabricated cables (cloth-based material winding)	1.5mm <sup>2</sup>	System Configuration
Master-slave communication cable	Prefabricated cables (cloth-based material winding)	1.5mm <sup>2</sup>	System Configuration
Grid access cables	Hard core copper conductor	35mm <sup>2</sup>	Customers self prepare

Table-Fixing diagram

### • Installation of battery cabinet cables



Before installing cables, ensure all electrical switches are turned off to prevent electric shock and ensure the safety of the installation personnel.

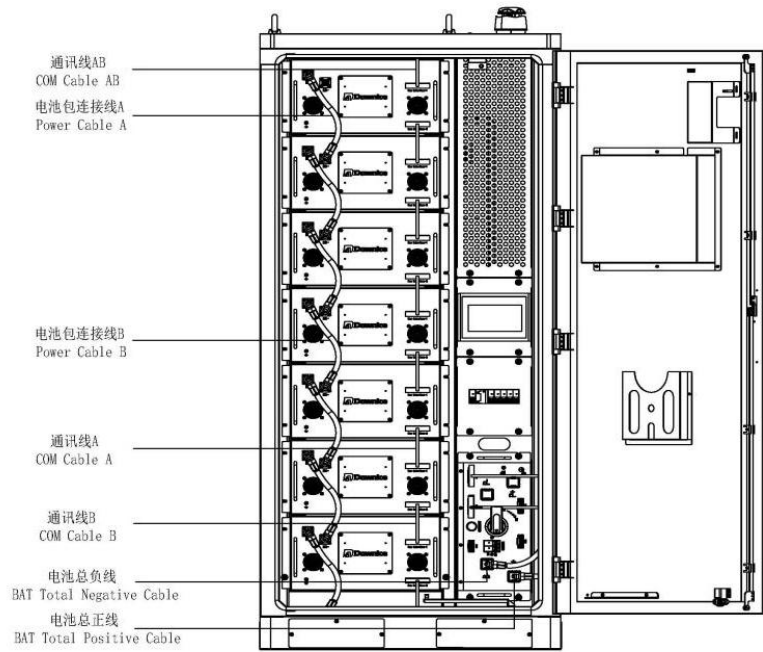

Figure-Harness installation diagram

Step 1: Check that the high-voltage cluster control box circuit breaker is in the "OFF" state

Step 2: Install the communication harness from the high-voltage cluster control box in sequence

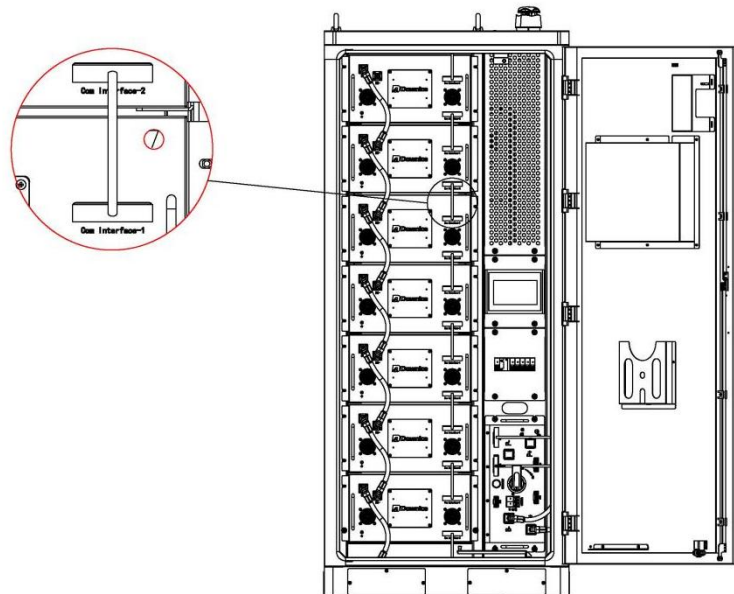

Figure-Diagram for disassembly and assembly of battery pack panel

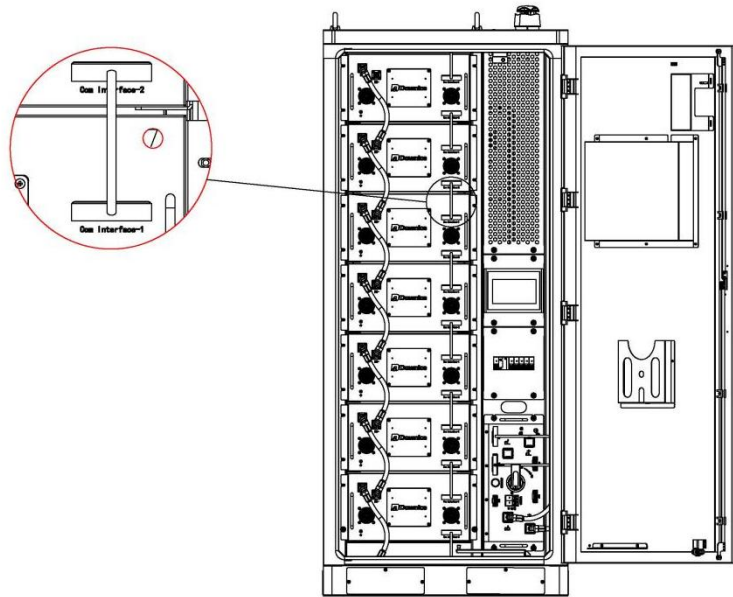

Figure-Installation diagram of battery pack connecting line

Step 3: Install the battery pack cables one by one

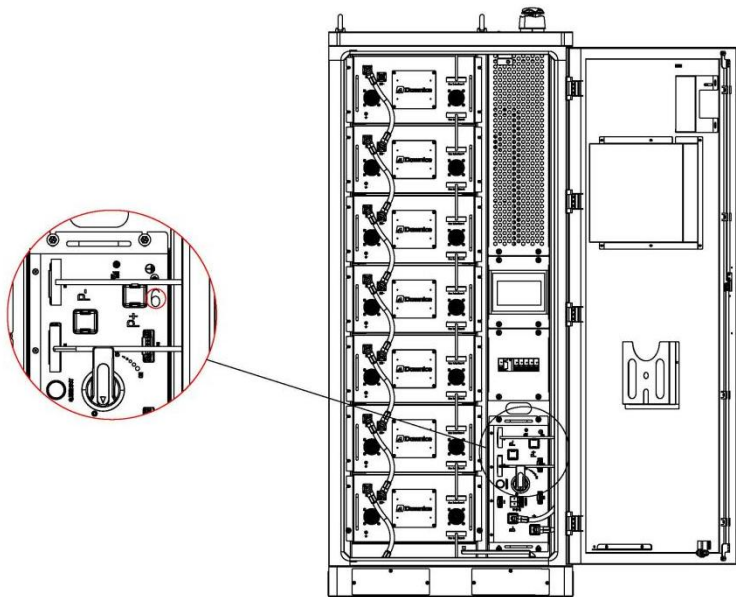

Figure-Diagram for disassembly and assembly of battery pack panel

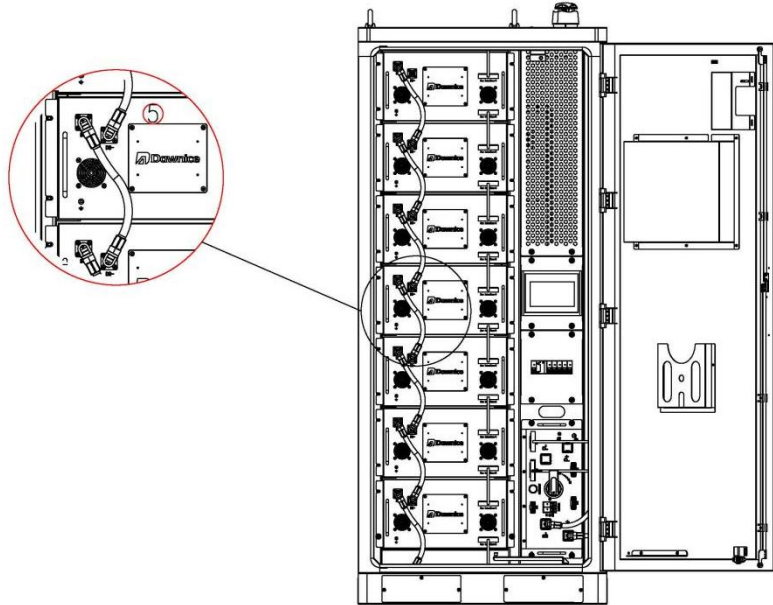
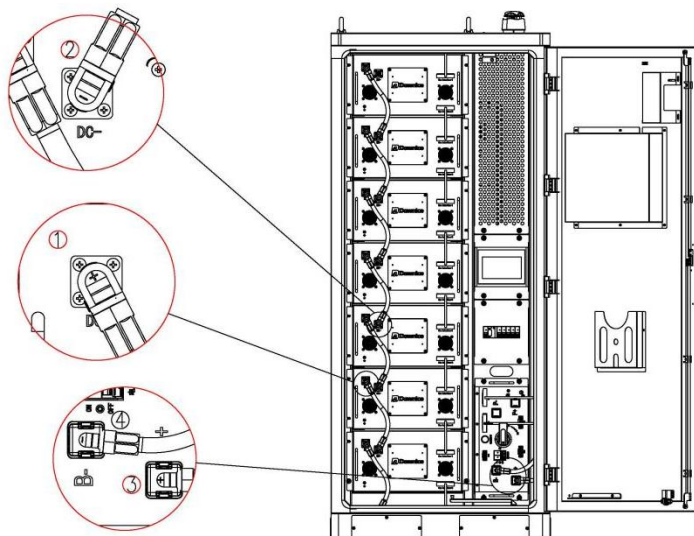

Figure Schematic diagram of battery pack connection cable installation

Step 4: Install the battery pack's total positive line; install terminal ④ first and then terminal ②

Step 5: Install the battery pack's total negative line; install terminal ③ first and then terminal ①



## 8.3 Grid-side cable installation

### Installation diagram:

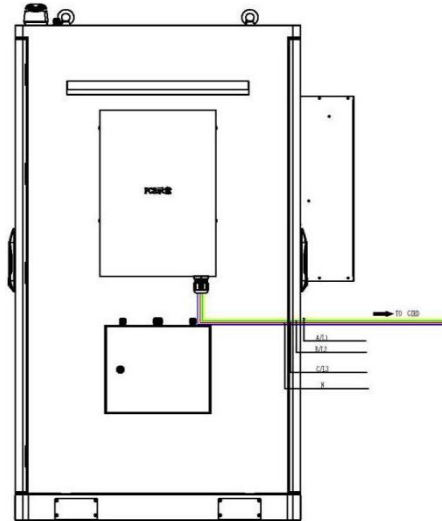

Figure Connection location of three-phase power grid

## 9. System power on

Note: This process is applicable for typical DC-side energy storage battery recommendations. For actual applications, please refer to the energy storage system operational requirements and local laws and regulations.

### • Inspection before powering on

No.	Inspection Items	Inspection Contents
1	Equipment appearance	<ul style="list-style-type: none"> <li>➤ The equipment appearance is intact and undamaged. If there is paint peeling, please repair the paint.</li> <li>➤ The equipment labels are clear and visible, and damaged labels should be replaced in time.</li> </ul>
2	Cable appearance	<ul style="list-style-type: none"> <li>● The cable protection layer is wrapped intact without obvious damage.</li> <li>● The conduit cable and hose are intact.</li> </ul>
3	Cable connection	<ul style="list-style-type: none"> <li>3 The cable connection position is the same as the design.</li> <li>4 The terminal production meets the specifications and the connection is firm and reliable.</li> </ul>
4	Cable routing	<ul style="list-style-type: none"> <li>3 Cut the wire buckle joints neatly without any exposed spikes or other phenomena.</li> <li>4 Leave a margin as required at the turning point and do not tighten it.</li> </ul>
5	Switch	<ul style="list-style-type: none"> <li>3 The external distribution cabinet switch is in the OFF state.</li> <li>4 The battery cluster switch is in the OFF state.</li> </ul>

Table-Inspection contents before powering on

### • Power on procedures

Steps	Item	Remark
1	Grid connected AC distribution cabinet power on	As shown in ①
2	AC distribution power on	As shown in ②
3	The energy storage system AC main switch is powered on	As shown in ③
4	Power on the AC distribution box of the energy storage system	As shown in ④
5	Battery cluster DC circuit breaker power on	As shown in ⑤
6	Cluster control box auxiliary power supply power on	As shown in ⑥

Note: Before closing any switch, necessary safety checks should be conducted

Table-Power on procedures

The position where this product located in the

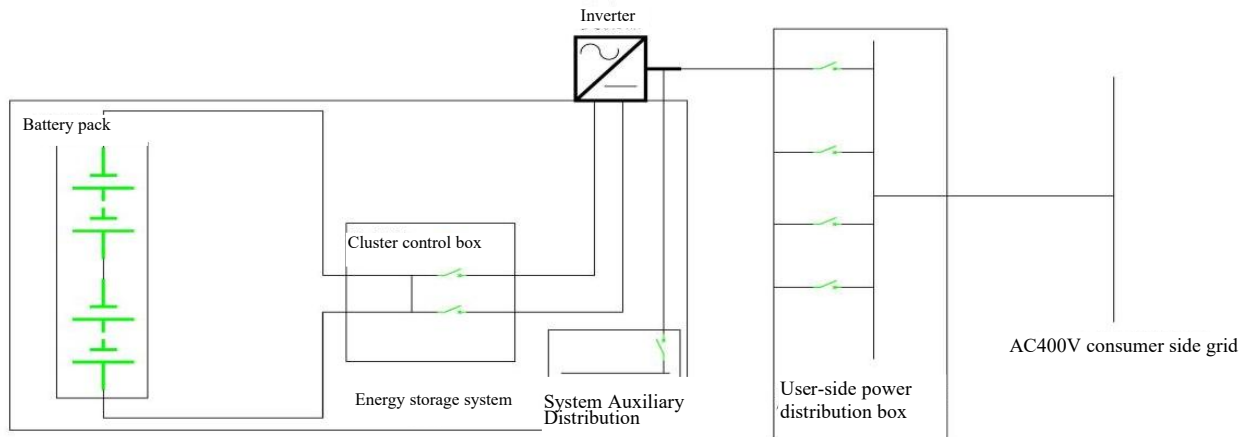

Figure-Power on procedures

### • AC-side power on

Prerequisite requirements:

- The pre-power on inspection has been completed.
- The operator is wearing personal protective equipment.
- Confirm that the three-phase voltage is within the normal range before closing the circuit breaker.
- Confirm that the three-phase electrical phase sequence is correct before closing the circuit breaker.

Operating steps:

- Step 1: close the single-phase switch of the remote protection control system (if any).
- Step 2: close the remote three-phase switch.
- Step 3: measure the input voltage with a multimeter to ensure that it is within the normal operating voltage range.
- Step 4: close the single-phase switch of the near end protection control system (if any).
- Step 5: close the near end three-phase switch.
- Step 6: measure the output voltage with a multimeter to ensure that it is within the normal operating voltage range.

——End

### • DC-side power on

Prerequisite requirements:

- 2 The pre-power on inspection has been completed.
- 3 The operator is wearing personal protective equipment.
- 4 Confirm that the AC main switch of the energy storage system is connected to the three-phase voltage within the normal range
- 5 Confirm that the AC main switch of the energy storage system is connected to the three-phase electrical phase sequence correctly
- 6 Confirm that the battery pack is connected correctly

- 7 Confirm that the battery pack, cluster control box, and inverter are connected correctly
- 8 Confirm that the power input/output protection cover of the cluster control box is securely closed

Operating steps:

- 2 Step 1: close the auxiliary distribution switch of the battery cabinet
- 3 Step 2: close the miniature circuit breaker of the cluster control box
- 4 Step 3: close the DC circuit breaker of the cluster control box

——End

## ● System power off

**Note:** This process is applicable for typical application scenario. For actual applications, please refer to the energy storage system operational requirements and local laws and regulations.

### • Issue a stop work command

Prerequisite requirements:

When the system is working normally, it is connected to the bus and operates with power

Operating steps:

- 2 Step 1: enter the command page of control devices such as PCS, inverters, EMS, etc.
- 3 Step 2: issue the "shutdown" command or control the system power to "0".
- 4 Step 3: enter the relevant device page and confirm that the system power is "0"; Confirm that the system has exited the charging and discharging state.
- 5 Step 4: use a clamp meter to measure and confirm that the system current is "0"

——End

### • Energy storage system power off

Operating steps:

- 2 Step 1: disconnect the distribution switches of the energy storage system in sequence
- 3 Step 2: disconnect the AC main switch of the energy storage system
- 4 Step 3: disconnect the DC main switch of the energy storage system

——End

### • AC distribution power off

Operating steps:

- 2 Step 1: disconnect the AC distribution switch
- 3 Step 2: disconnect the power distribution switch of the grid connection point

——End

## ● System maintenance

### • Maintenance instruction

With the increase of service life and the influence of environmental temperature, humidity, dust, and vibration, the components inside the energy storage system will age, which will affect the performance of the energy storage system and even lead to malfunctions that cannot function properly.

Therefore, it is necessary to implement daily and regular maintenance on the energy storage system to ensure its normal operation and service life. All measures and methods that contribute to the good working condition of energy storage systems belong to the scope of maintenance work.

In case of fault, please contact our company. At the same time, provide the following information to provide you with better service:

- Photos of the fault site.
- Model and serial number of the faulty product.
- Information on relevant components connected to the product.
- Installation and connection plan for energy storage system.
- Fault information and brief description.

### • Maintenance precautions

#### Warning

Only personnel who have received relevant training and qualifications can perform maintenance operations on the energy storage system.



#### Note

When performing maintenance, avoid leaving metal items such as screws and washers inside the energy storage system to prevent potential damage to the system.

When servicing and maintaining the energy storage system, safety should be the top priority. To protect the operators, the following rules must be followed:

1. Disconnect the external connection of the energy storage system.
2. Ensure that the energy storage system is not accidentally powered on.
3. Before maintenance, use a multimeter to measure and ensure that the components being maintained are not electrified.
4. Ensure that the system is well grounded.

### • Maintenance work

Maintenance Item	Maintenance Content	Recommended Period
Record keeping	Export data via USB and save backup.	One month
System inspection	Observe the appearance of the energy storage system for any damage, deformation, or rust. Observe various parameters during operation. Use a thermal imaging device or other detection system to monitor the heating situation. Check whether the ventilation, ambient temperature, humidity, dust	Three months

	and other environmental conditions around the inverter meet the requirements.	
Air conditioning service	Check for dust. Use compressed air for cleaning. Replace the air filter screen.	Three months
Safety function	Check whether the emergency stop button is faulty. Check whether the command issuance function is faulty.	Six months
Identification inspection	Check the warning signs and other equipment identifications on the machine body. If they are found to be blurry or damaged, please replace them in time	Six months
Electrical connection	Check all electrical connections for looseness or poor contact. Check whether all cables and metal surfaces in contact with the skin are damaged or scratched. Check whether the insulation wrapping tape of all wiring terminals has fallen off Check for signs of overheating in the screw position. Check whether there is any color change in the wiring copper bars and screws.	Twelve month
Circuit breaker maintenance	Check the circuit breakers for failure. Check whether the circuit breaker or load switch is damaged.	Twelve month

Table-Maintenance work contents

**Yichun Vesol Manufacture and Trade Co., Ltd.**

Add.: Building 15, Economic Industrial Park, Yuanzhou Economic and Technological  
Development Zone, Yuanzhou District, Yichun City, Jiangxi Province, China  
Postcode: 336000

※ The product information and parameters are subject to change without prior notice