



User's Manual

Energy Storage battery System

HZEB-LCT-10 (Stacked)

Contents

| | |
|--|----|
| 1. Foreword | 4 |
| 1.1 Applicable products | 4 |
| 1.2 Applicable personnel | 4 |
| 1.3 Legal statement | 4 |
| 1.4 Revision history | 5 |
| 2. Safety | 6 |
| 2.1 Safety precautions | 6 |
| 2.2 Safety measures | 7 |
| 3. Product Introduction | 9 |
| 3.1 Product characteristics | 9 |
| 3.2 Product identification | 10 |
| 3.3 Specifications and parameters | 11 |
| 3.4 Appearance | 12 |
| 3.5 Appearance description | 12 |
| 4. Storage and Packaging | 14 |
| 4.1 Inspection before signing for acceptance | 14 |
| 4.2 Inspection of parts and components | 14 |
| 4.3 Device storage | 15 |
| 5. System Installation | 16 |
| 5.1 Installation requirements | 16 |
| 5.2 Installation | 17 |
| 5.3 Wiring of single-battery system | 20 |
| 5.3.1 Overview map of single-battery system wiring | 20 |
| 5.3.2 Power line connection | 21 |
| 5.3.3 Communication line connection | 22 |

| | |
|---|----|
| 5.3.4 Address dialing | 23 |
| 5.4 Wiring of multi-battery system | 24 |
| 5.4.1 Overview map of multi-battery system wiring | 24 |
| 5.4.2 Power line connection | 25 |
| 5.4.3 Communication line connection | 25 |
| 5.4.4 Address dialing | 25 |
| 6. System Operating | 26 |
| 6.1 Inspection before powering on | 26 |
| 6.2 Battery power-on | 26 |
| 6.3 System operating topology | 27 |
| 6.4 Indicators | 28 |
| 6.5 Battery power-off | 29 |
| 7. Maintenance | 30 |

1. Foreword

This Manual introduces the LCT series products of Yichun Vesol Manufacture and Trade Co., Ltd. (hereinafter referred to as the "Vesol").LCT-10 is a lithium iron phosphate (LFP) battery storage system. Please readthis Manual before installing the battery and operate carefully in accordancewith it during installation. If you have any questions, please contact Vesol for advices and explanations.

1.1 Applicable products

This Manual applies to the following model:

HZ-LCT-10

1.2 Applicable personnel

This Manual is only applicable to the professionals who are familiar with local regulations, standards, and electrical systems, have received professional training, and are familiar with the relevant knowledge of this product.

1.3 Legal statement

The copyright of this Manual belongs to Vesol. Without the prior writtenauthorization of Vesol, no part of this Manual may be extracted, duplicated,translated, annotated or copied in any form or manner.

All rights reserved by Vesol. This product meets the design requirements forbasic environmental protection and personal safety. The product shall be stored,used, and disposed of in accordance with the product manual, relevant contractsor relevant laws and regulations.

Please note that our company may make modifications to contents of this

Manual without prior notice. If any changes are made to its information, we will not notify you separately.

1.4 Revision history

The latest version in the "Revision history" contains updates from all previous versions of this Manual.

V1.0.0.20240719

- First issue

2. Safety

2.1 Safety precautions

Before proceeding with any work, please read all safety instructions carefully and follow them when operating the battery.

Incorrect operation may result in:

- Injury or death of operators or third parties.
- Damage to the system hardware.

Skills that qualified personnel shall have:

- Training in installation, debugging, and hazard handling of electrical system.
- Understanding of this Manual and other related documents.
- Understanding of local regulations and directives.

Following symbols are used in this Manual to highlight important information:



Warning: Indicates a dangerous situation. If not avoided, it may lead to death or serious injury.



Caution: Indicates possible damage or injury. If not avoided, it may result in minor injury or property damage.



Notice: Indicates that there may be a risk of damage to the product.

2.2 Safety measures

Tips

1. It is very important and necessary to read this User's Manual carefully before installing or using the battery. Failure to follow any instructions or warnings in this Manual may result in electric shock, serious injury, or death, or may damage the battery, causing it to fail. Damage caused by improper operations mentioned above is not covered under the warranty of this product.
2. If the battery is to be stored for a long time, it needs to be recharged every six months to a SOC level not less than 90%.
3. The battery shall be recharged within 12 hours after complete discharge.
4. The power terminals must not be connected in reverse.
5. All battery power terminals must be disconnected during maintenance.
6. In case of any abnormality, please contact the supplier within 24 hours.
7. Do not clean the battery with any detergents.
8. Do not expose the battery to flammable or irritating chemicals or vapors.
9. Do not directly connect the battery to the photovoltaic solar line.
10. Never insert any foreign object into any part of the battery.
11. The direct or indirect damage due to above reasons are not covered under the warranty.

Warning

Before connecting:

1. Please check the product and packing list after unpacking. If the product is damaged or any part is missed, please contact your local dealer.

2. Before installation, please make sure to cut off mains supply and ensure that the battery is turned off.
3. Make sure that the wiring is correct, do not mistake positive and negative terminals of the cable, and ensure that no short circuit is caused to any external device.
4. Never connect the battery directly with the AC power supply.
5. Do not connect the battery in series as the embedded BMS in the battery is of 51.2 V DC design.
6. The battery must be grounded in a way that the resistance is less than 0.10 MΩ.
7. Please ensure that electrical parameters of the battery system are compatible with the relevant devices.
8. Please keep the battery away from water and fire sources.

 **Notice****During use:**

1. If it is necessary to move or repair the battery system, be sure to cut off the power and completely turn off the battery.
2. Never connect the battery with other different types of batteries.
3. Never connect the battery with a faulty or incompatible inverter.
4. Never disassemble the battery.
5. Do not open, repair, or disassemble the battery, except for staff or authorized personnel. Our company shall not be liable for any consequences or related liabilities arising from violations of safety operations or design, production, and safety standards of equipment.
6. Never connect this product with other models in parallel.

3. Product Introduction

HZ-LCT, the latest 51.2 V low-voltage DC energy storage system product (hereinafter referred to as "this product") developed by Vesol, can provide reliable power support for residential buildings and is a good partner for environmentally friendly living.

This product shall be used in conjunction with a low-voltage inverter, and is compatible with mainstream brand inverters available on the market.

For this series of products, up to 5 batteries can be used in a stacked manner.

3.1 Product characteristics

This system has following functional characteristics:

1. High voltage accuracy (≤ 20 mV)
2. High current accuracy ($\leq 2\%$ @FS)
3. Short-circuit protection
4. Adjustable over-current protection
5. Adjustable parameter settings
6. LED indication of product status
7. Charging equilibrium
8. Flexible configuration (multiple batteries can be connected in parallel to expand capacity)
9. Self-cooling mode (both noise and power consumption of the system itself are reduced significantly)

3.2 Product identification

| | |
|--|---------------------------|
|  Dawnice Energy Storage Battery Pack | |
| Model:HZEB-LCT-10 | Cell Type:LiFePo4 |
| Rated voltage:DC51.2V | Voltage range:44.8V-57.6V |
| Energy: 10.547kWh | Capacity:206Ah |
| Recharging current:<100A | Discharge current:<100A |
| Working humidity:0~90% (non-condensing) | |
| Working temperature:-10℃~+55℃ | |
| Protection Level:IP20 | |
| Date of manufacture:2024.6.1 | |
| Manufacturer: Yichun Dawnice Manufacture and Trade Co.,Ltd | |

Interpretation of labels



Do not place near open flames or in the fire



Do not place in a damp environment



Do not dispose of discarded batteries in the trash can and have them recycled by professionals or organizations



MSDS material inspection certification mark

UN38.3 Dangerous goods transportation certification mark

3.3 Specifications and parameters

| Model | HZEB-LCT-10 |
|-----------------------------------|--|
| Cell type | LiFePO4 |
| Rated power | 10547Wh |
| Rated capacity | 206Ah |
| Rated voltage | 51.2V |
| Working voltage | 44.8~57.6V |
| Charge-discharge rate | 0.5C |
| Standard charge-discharge current | 100A |
| Maximum charge-discharge current | 100A |
| Battery dimensions | 750*450*260 |
| Base dimensions | 750*450*57 |
| Battery weight | 102kg |
| Protection level | IP20 |
| Charge temperature range | 0~55°C |
| Discharge temperature range | -10~55°C |
| Cycle life | ≥3,000 times 25°C±2°C, 100% DOD 0.5 C, 80% SOH |
| Communication mode | CAN/RS485 |
| Expandability | Up to 15 modules can be connected in parallel |
| Protection | Short circuit protection, overcharge protection, discharge protection, overcurrent protection, over temperature protection |
| Certification | MSDS/UN38.3 |
| Compatible inverter | Growatt/Deye/Schneider/GoodWe/MEGAREVO, etc. |

3.4 Appearance

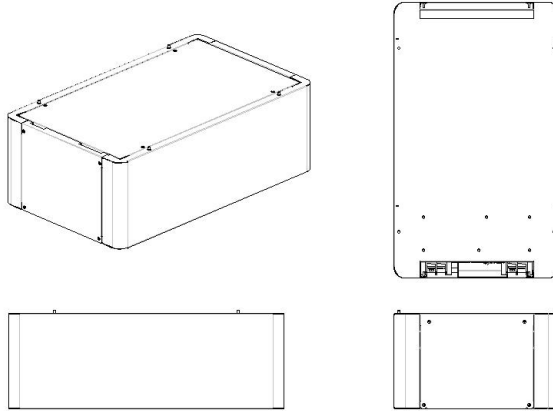

3.5 Appearance description

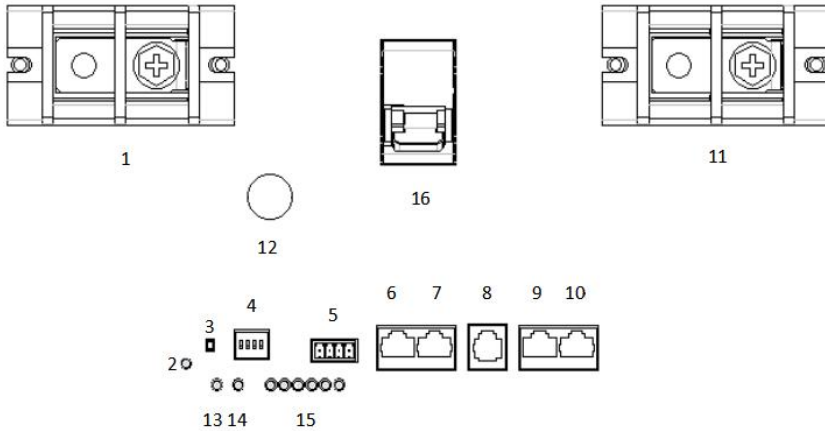

| No. | Interpretation | Description |
|-----|----------------|---|
| 1 | DC+ | Battery power interface positive terminal |
| 2 | ON/OFF | Battery switch indicator |
| 3 | RST | Reset button |
| 4 | ADD | Dial switch |
| 5 | Dry Contact | Dry contact |

| | | |
|----|-----------------|---|
| 6 | RS485 | Inverter RS485 communication port |
| 7 | CAN | Inverter CAN communication port |
| 8 | RS232 | Upper computer communication port |
| 9 | RS485 | Battery parallel operation port 1 |
| 10 | RS485 | Battery parallel operation port 2 |
| 11 | DC- | Battery power interface negative terminal |
| 12 | ON/OFF switch | Protection board power switch |
| 13 | RUN | Battery running indicator |
| 14 | ALM | Battery warning indicator |
| 15 | SOC | Battery power indicator |
| 16 | Circuit breaker | Power switch of battery power interface |

4. Storage and Packaging

4.1 Inspection before signing for acceptance

Before signing for this product, please check it carefully as follows:

1. Check the outer packaging for any damage, such as deformation, holes, cracks or other signs that may cause damage to the device inside the packaging box. If there is any damage, please contact your dealer without opening the package.
2. Check whether the device model is correct. If there is any discrepancy, please contact your dealer without opening the package.
3. Check whether the type and quantity of the delivered parts are correct and whether there is any damage in appearance. If there is any damage, please contact your dealer.

4.2 Inspection of parts and components

Before installing this product, please check the following parts and components carefully:

1. Battery
2. Connecting copper bar
3. Copper bar gasket
4. Primary harness
5. Communication harness
6. Manual
7. Battery base

4.3 Device storage

If the device will not be immediately put into operation, please store it according to the following requirements:

1. Make sure that the outer packaging box is not removed and that the desiccant inside the box is not lost.
2. It is recommended to complete installation of the device within 3 days after removing the packaging box. If the device is not installed, it shall be repackaged in the original packaging box for storage.
3. Keep away from flammable, explosive, and corrosive environments and items during storage.
4. Be sure to store it in a cool and shaded place, and avoid direct sunlight.
5. Recommended SOC range during storage: 30%–60%. A charge-discharge cycle shall be carried out every 3 months.
6. Storage temperature range:
 - When $-20^{\circ}\text{C} \leq$ the temperature $< 10^{\circ}\text{C}$, the storage time shall not exceed 1 month.
 - When $10^{\circ}\text{C} \leq$ the temperature $\leq 35^{\circ}\text{C}$, the storage time shall not exceed 1 year.
 - When $35^{\circ}\text{C} <$ the temperature $\leq 55^{\circ}\text{C}$, the storage time shall not exceed 1 month.
7. Storage humidity range: 0%–90% RH without condensation. If any moisture or condensation is found at the battery interface, the battery system shall not be installed.

5. System Installation

5.1 Installation requirements

Installation environment requirements:

1. The device shall not be installed in flammable, explosive, or corrosive environments.
2. The device shall be installed at a location that is far away from water pipes and cables inside the walls to avoid dangers during drilling.
3. The installation environment shall avoid direct sunlight, rain, snow accumulation, etc. It is recommended to install in a sheltered location. If necessary, a sunshade can be built.
4. The installation space must meet the ventilation and heat dissipation requirements of the device and the operation space requirements.
5. The device shall have a protection level that meets the requirements for indoor installation, and the temperature and humidity of the installation environment shall be kept within their respective appropriate ranges.
6. The installation height of the device shall facilitate operation and maintenance, ensuring that the device's indicators and labels are easily visible and that the terminal connectors are easily accessible.
7. The device shall be installed at an altitude below 2,000 m (the highest working altitude).
8. The device shall be kept away from strong magnetic field environments to avoid electromagnetic interference. If the installation location is close to a radio station or wireless communication device below 30 MHz, make sure that the battery is kept 30 m away from such device that generates wireless electromagnetic interference.

5.2 Installation



Note: The battery installation shall be performed by two people

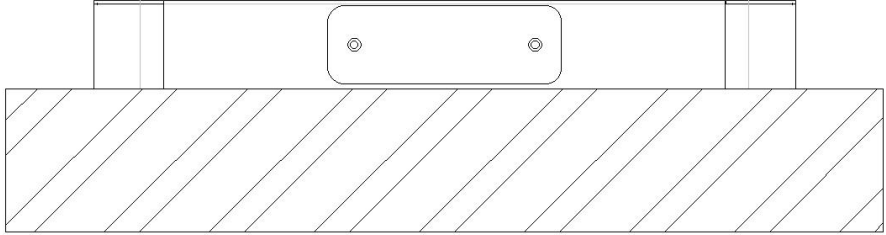

Step 1 Place the battery base on the ground

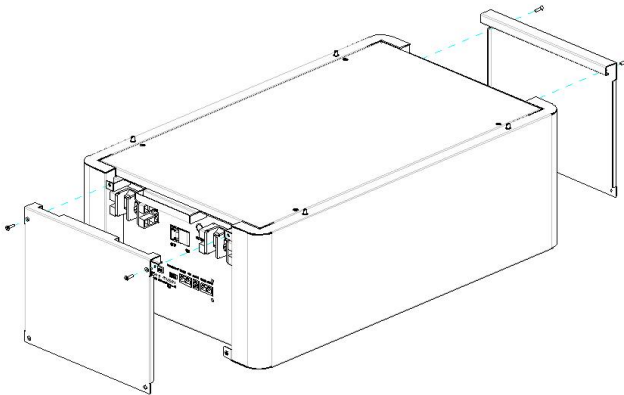

Step 2 Remove the side panels on both sides of the battery

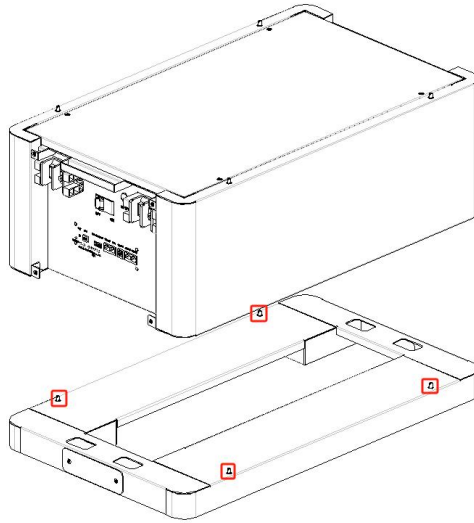

Step 3 Align with the locating pins on the base and stack the battery onto the base

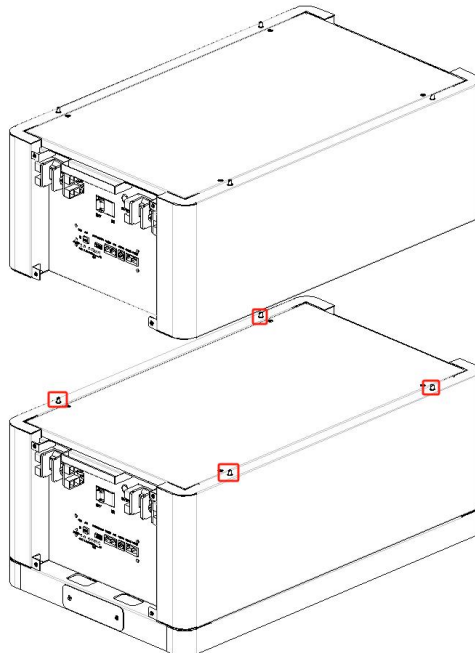

Step 4 Align with the locating pins on the battery, stack another battery onto the previous one, ensuring the orientation is consistent, and repeat the process up to a maximum of 5 layers

Step 5 Wire according to 5.4.1

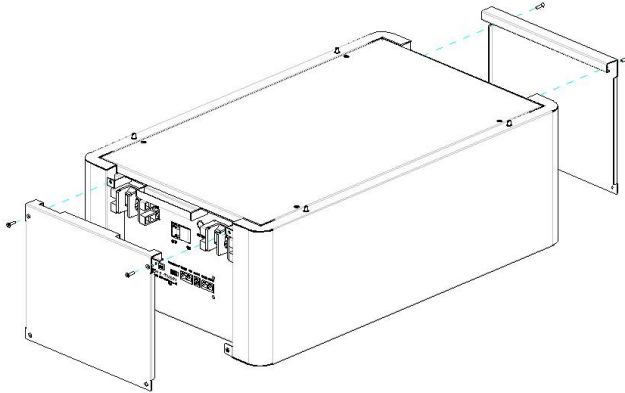

Step 6 Install the side panels back to the battery

5.3 Wiring of single-battery system

5.3.1 Overview map of single-battery system wiring

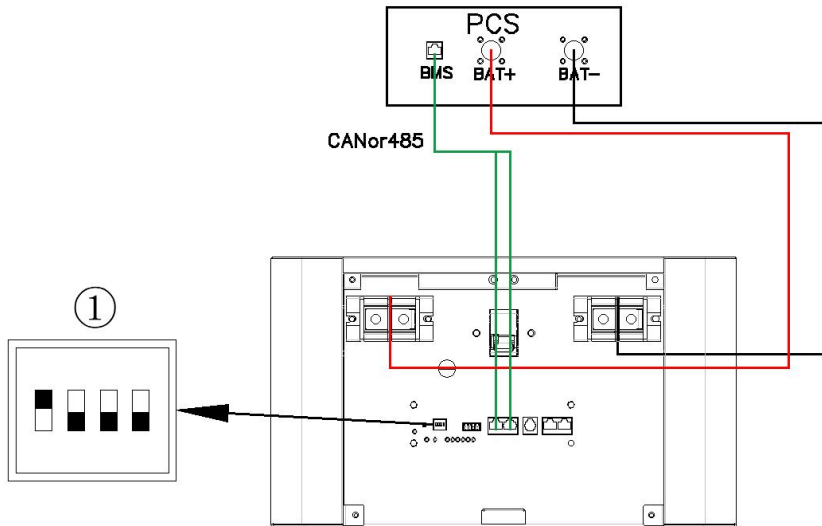

5.3.2 Power line connection

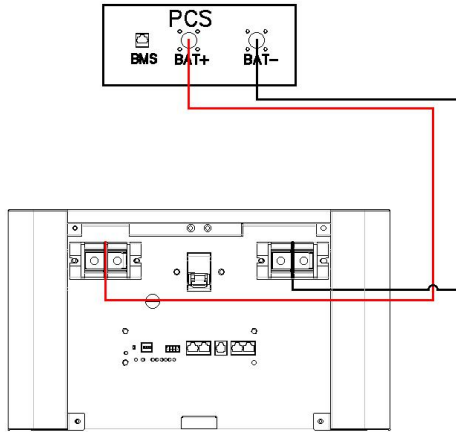

Step 1 Connect the battery DC+ to the inverter DC+/BAT+

Step 2 Connect the battery DC- to the inverter DC-/BAT-

5.3.3 Communication line connection

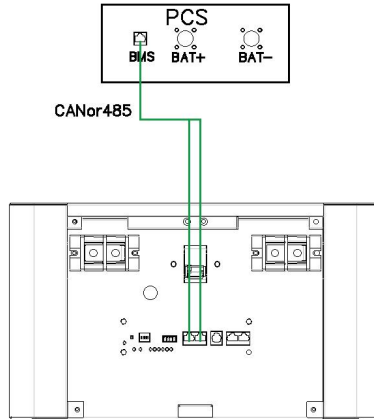

Step 1 Insert one end of the RJ45 communication line into the communication interface (CAN or RS485) of the battery host inverter

Step 2 Insert the other end of the RJ45 communication line into the communication interface (BMS, CAN, or RS485) of the inverter battery

Definition of communication interfaces:

RJ45 Registered Jack

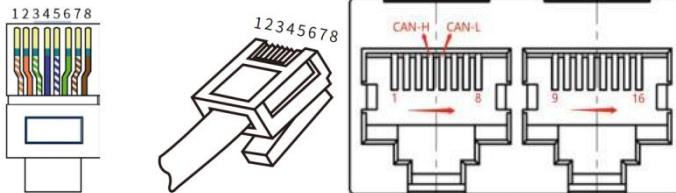

| CAN -- 8P8C vertical RJ45 socket | | RS485 -- 8P8C vertical RJ45 socket | |
|----------------------------------|---------------------------|------------------------------------|---------------------------|
| RJ45 pin | Description of definition | RJ45 pin | Description of definition |
| 1, 3, 6, 7, 8 | NC | 9, 16 | RS485-B1 |

| | | | |
|---|-------|--------|----------|
| 4 | CAN-H | 10, 15 | RS485-A1 |
| 5 | CAN-L | 11, 14 | GND |
| 2 | GND | 12, 13 | NC |

5.3.4 Address dialing

When a single battery is used, the battery address (ADD) shall be set to 1 by DIP switch, as shown in the following figure.

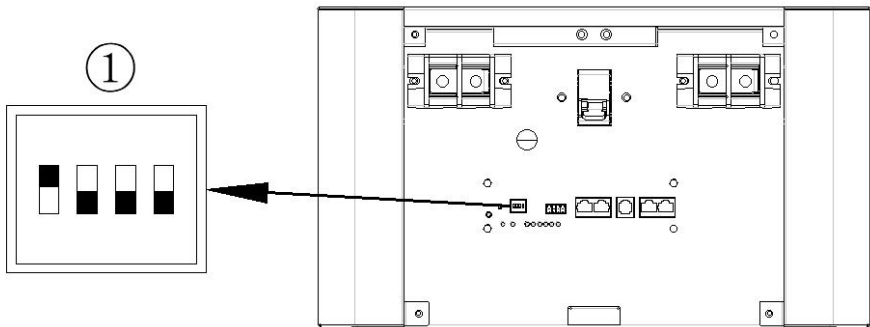

5.4 Wiring of multi-battery system

i Note: When multiple batteries are connected in parallel, the host (i.e. No.1 battery) shall be connected to the inverter for communication

5.4.1 Overview map of multi-battery system wiring

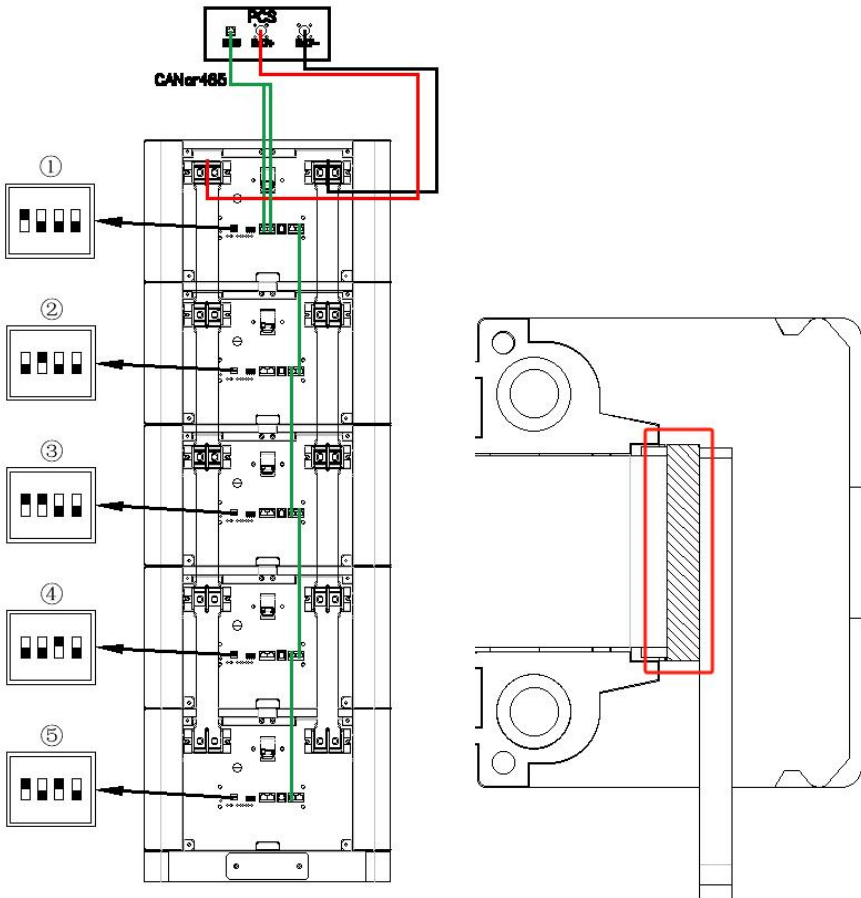

If the bottom of the last battery's connecting copper bar appears to be suspended, install the copper bar gasket that comes with the package underneath the copper

bar.

5.4.2 Power line connection

See 5.3.2

5.4.3 Communication line connection

See 5.3.3

5.4.4 Address dialing

When multiple batteries are connected in parallel for use, address (ADD) of each battery shall be kept different and sorted correctly to ensure normal operation of the system. For setting and definition of the DIP switch, please refer to the following table.

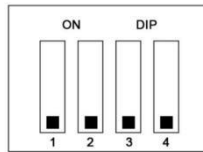

| ADD | DIP switch position | | | |
|-----|---------------------|-----|-----|-----|
| | #1 | #2 | #3 | #4 |
| 1 | ON | OFF | OFF | OFF |
| 2 | OFF | ON | OFF | OFF |
| 3 | ON | ON | OFF | OFF |
| 4 | OFF | OFF | ON | OFF |
| 5 | ON | OFF | ON | OFF |

6. System Operating

6.1 Inspection before powering on

Before the battery system is powered on, be sure to check it according to the following requirements to prevent any damage to the system.

1. The inverter shall be installed firmly at a position that is easy to operate and maintain, a space that is conducive for ventilation and heat dissipation, and a clean and tidy environment.
2. The power lines and communication lines shall be connected correctly and firmly.
3. The cables shall be tied in a way that the routing requirements are met, distribution is reasonable, and no damage will be caused.

6.2 Battery power-on



Note: The circuit breakers between inverter and battery and between batteries shall be installed according to local laws and regulations.

Step 1 Close the battery circuit breaker.

Step 2 Press the battery button switch.

Step 3 Close the circuit breaker between the battery and the inverter. (Optional)

Step 4 Power on the inverters used in the system. For detailed operation, please refer to the user's manual of the inverter of corresponding model.

Step 5 Close the air switch of the load.

6.3 System operating topology

Single-battery system:

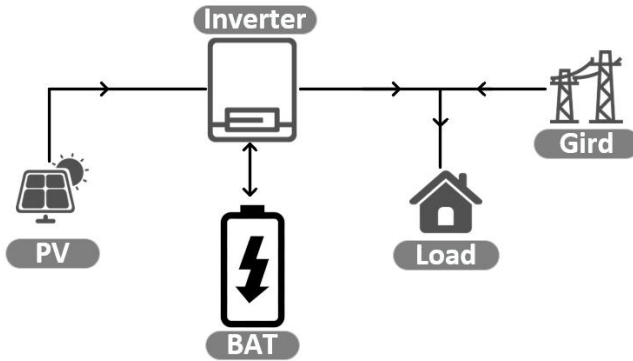

Multi-battery system:

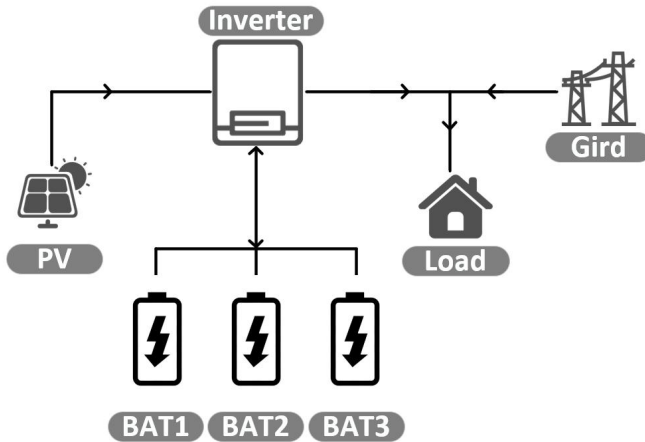

6.4 Indicators



Description of indicators

| Status | Normal/Alarm/Protection | ON/OFF | RUN | ALM | Power Indicator LED | | | | | | Description | |
|-------------|---|-----------|-------------------|-------------------|---|-----------|-----------|-----------|-----------|-----------|--|--|
| | | ● | ● | ● | ● | ● | ● | ● | ● | ● | | |
| Power-off | Sleep | OFF | OFF | OFF | OFF | OFF | OFF | OFF | OFF | OFF | OFF | All OFF |
| Standby | Normal | Always ON | Flash once | OFF | Depend on battery power | | | | | | Standby status | |
| | Alarm | Always ON | Flash once | Flash three times | Depend on battery power | | | | | | Voltage of module(s) is low | |
| Charging | Normal | Always ON | Always ON | OFF | Depend on battery power (The LED indicating the highest power level flashes twice) | | | | | | The LED indicating the highest power level flashes (twice), and ALM does not flash when an overcharge alarm is given | |
| | Alarm | Always ON | Always ON | Flash three times | Depend on battery power (The LED indicating the highest power level flashes twice) | | | | | | | |
| | Overcharge protection | Always ON | Always ON | OFF | Always ON | Always ON | Always ON | Always ON | Always ON | Always ON | Always ON | If no mains power is available, the indicator switches to standby status |
| | Temperature protection, overcurrent protection, and fail-safe | Always ON | OFF | Always ON | OFF | OFF | OFF | OFF | OFF | OFF | OFF | Charging will be stopped |
| Discharging | Normal | Always ON | Flash three times | OFF | Depend on battery power | | | | | | | |
| | Alarm | Always ON | Flash three times | Flash three times | Depend on battery power | | | | | | | |
| | Under-voltage protection | Always ON | OFF | OFF | OFF | OFF | OFF | OFF | OFF | OFF | OFF | Discharging will be stopped |
| | Temperature protection, overcurrent protection, short-circuit | Always ON | OFF | Always ON | OFF | OFF | OFF | OFF | OFF | OFF | OFF | Discharging will be stopped |

| | | | | | | | | | | | | |
|---------|--|-----|-----|-----------|-----|-----|-----|-----|-----|-----|-----|--|
| | protection, reverse connection protection, fail-safe | | | | | | | | | | | |
| Failure | | OFF | OFF | Always ON | OFF | OFF | OFF | OFF | OFF | OFF | OFF | Charging and discharging will be stopped |

Description of power indicator

| Status | | Charging | | | | | | Discharging | | | | | |
|---------------------|------------|-------------|-------------|-------------|-------------|-------------|-------------|---------------------|-----------|-----------|-----------|-----------|-----------|
| Capacity indicator | | L6 | L5 | L4 | L3 | L2 | L1 | L6 | L5 | L4 | L3 | L2 | L1 |
| Battery power (%) | 0~16.6% | OFF | OFF | OFF | OFF | OFF | Flash twice | OFF | OFF | OFF | OFF | OFF | Always ON |
| | 16.6~33.2% | OFF | OFF | OFF | OFF | Flash twice | Always ON | OFF | OFF | OFF | OFF | Always ON | Always ON |
| | 33.2~49.8% | OFF | OFF | OFF | Flash twice | Always ON | Always ON | OFF | OFF | OFF | Always ON | Always ON | Always ON |
| | 49.8~66.4% | OFF | OFF | Flash twice | Always ON | Always ON | Always ON | OFF | OFF | Always ON | Always ON | Always ON | Always ON |
| | 66.4~83.0% | OFF | Flash twice | Always ON | Always ON | Always ON | Always ON | OFF | Always ON | Always ON | Always ON | Always ON | Always ON |
| | 83.0~100% | Flash twice | Always ON | Always ON | Always ON | Always ON | Always ON | Always ON | Always ON | Always ON | Always ON | Always ON | Always ON |
| Running indicator ● | | Always ON | | | | | | Flash (three times) | | | | | |

6.5 Battery power-off

To power off the battery system, please follow the following steps:

- Step 1 Press the button switch
- Step 2 Make sure that the indicator is off
- Step 3 Disconnect the battery circuit breaker
- Step 4 Disconnect the distribution circuit breaker

7. Maintenance

| Maintenance Item | Maintenance Interval |
|---|----------------------|
| If the battery is not put into use, it shall be fully charged and then discharged to 30%–60%. | Once every 3 months |
| Check whether the wall mount bracket is installed loose. If so, please tighten the corresponding position. | Once every 6 months |
| Check whether the case is damaged. If so, please repair the paint or contact for after-sales service. | Once every 6 months |
| Check the exposed cables for wear. If wear is found, replace the corresponding cable or contact for after-sales service. | Once every 6 months |
| Check whether any debris piled up around the battery. If any, please clean it to avoid heat dissipation of the battery from being affected. | Once every 6 months |
| Check whether any water or pests enter into the battery to avoid the battery from being invaded for a long period of time. | Once every 6 months |



Warning:

- If any problems are found to have an impact on the battery or the battery and energy storage inverter system, please contact our after-sales personnel, and do not disassemble it without authorization; any damage caused by unauthorized disassembly shall be borne by the disassembling party.
- If the copper conductor inside any conductive wire is found to be exposed, do not touch it as the high voltage is dangerous, please contact our after-sales personnel, and do not disassemble it without authorization.
- In case of other emergencies, please contact our after-sales personnel at the first time, and operate by professionals under the guidance of our after-sales personnel.

Yichun Vesol Manufacture and Trade Co., Ltd.

Add.: Building 15, Economic Industrial Park, Yuanzhou Economic and
Technological Development Zone, Yuanzhou District, Yichun City, Jiangxi
Province, China

Postcode: 336000

※ The product information and parameters are subject to change without prior notice