



User Manual

Energy Storage Battery

HZEB-LCT-2.5

Contents

1. Foreword.....	4
1.1 Applicable products.....	4
1.2 Applicable personnel.....	4
1.3 Legal statement.....	4
1.4 Revision history.....	5
2. Safety.....	6
2.1 Safety precautions.....	6
2.2 Safety measures.....	7
3. Product Introduction.....	9
3.1 Product characteristics.....	9
3.2 Product identification.....	10
3.3 Specifications and parameters.....	11
3.4 Appearance.....	12
3.5 Appearance description.....	12
3.5.1 Definition of control panel.....	12
3.5.2 Battery switch.....	13
3.5.3 Signal communication panel.....	13
4. Storage and Packaging.....	14
4.1 Inspection before signing for acceptance.....	14
4.2 Inspection of parts and components.....	14
4.3 Device storage.....	15
5. System Installation.....	15
5.1 Installation requirements.....	16
5.2 Installation of wall-mounted bracket.....	16
5.3 Wiring of single-battery system.....	19
5.3.1 Overview map of single-battery system wiring.....	19
5.3.2 Power line connection.....	20
5.3.3 Communication line connection.....	20
5.3.4 Address dialing.....	21
5.4 Wiring of multi-battery system.....	22

5.4.1 Overview map of multi-battery system wiring.....	22
5.4.2 Power line connection.....	23
5.4.3 Communication line connection.....	23
5.4.4 Address dialing.....	23
6. System operation.....	25
6.1 Inspection before powering on.....	25
6.2 Battery power-on.....	25
6.3 System operating topology.....	26
6.4 Battery protocol selection.....	27
6.5 Indicator lamp status.....	28
6.6 Battery power-off.....	30
7. Maintenance.....	31

1. Foreword

This Manual introduces the LCT series products of Vesol. HZEB-LCT-2.5 is a lithium iron phosphate (LFP) battery storage system. Please read this Manual before installing the battery and operate carefully in accordance with it during installation. If you have any questions, please contact Vesol for advice and explanations.

1.1 Applicable products

This document applies to the following models:

HZEB-LCT-2.5

1.2 Applicable personnel

This Manual is only applicable to the professionals who are familiar with local regulations, standards, and electrical systems, have received professional training, and are familiar with the relevant knowledge of this product.

1.3 Legal statement

The copyright of this Manual belongs to Vesol. Without the prior written authorization of Vesol, no part of this Manual may be extracted, duplicated, translated, annotated or copied in any form or manner. All rights are reserved by Vesol. This product meets the design requirements for basic environmental protection and personal safety. The product shall be stored, used, and disposed of in accordance with the product manual, relevant contracts or relevant laws and regulations. Please note that Vesol may make modifications to contents of this Manual without prior notice. If any changes are made to the information, we will not notify you separately.

1.4 Revision history

The latest version in the "Revision history" contains updates from all previous versions of the document.

V1.0.0.20240816

➤ First issue

2. Safety

2.1 Safety precautions

Before proceeding with any work, please read all safety instructions carefully and follow them when operating the battery.

Incorrect operation may result in:

- Injury or death of operators or third parties.
- Damage to the system hardware.

Skills that qualified personnel shall have:

- Training in installation, debugging, and hazard handling of electrical system.
- Understanding of this Manual and other related documents.
- Understanding of local regulations and directives.

Following symbols are used in this Manual to highlight important information:



Warning: Indicates a dangerous situation. If not avoided, it may lead to death or serious injury.



Caution: Indicates possible damage or injury. If not avoided, it may result in minor injury or property damage.



Notice: Indicates that there may be a risk of damage to the product.

2.2 Safety measures



Tips

1. It is very important and necessary to read this User's Manual carefully before installing or using the battery. Failure to follow any instructions or warnings in this document may result in electric shock, serious injury, or death, or may damage the battery, causing it to fail. Damage caused by improper operations mentioned above is not covered by the warranty of this product.
2. If the battery is to be stored for a long time, it needs to be recharged every six months to a SOC level not less than 90%.
3. The battery shall be recharged within 12 hours after complete discharge.
4. The power terminals must not be connected in reverse.
5. All battery power terminals must be disconnected during maintenance.
6. In case of any abnormality, please contact the supplier within 24 hours.
7. Do not clean the battery with any detergents.
8. Do not expose the battery to flammable or irritating chemicals or vapors.
9. Do not directly connect the battery to the photovoltaic solar line.
10. Never insert any foreign object into any part of the battery.
11. The direct or indirect damage due to above reasons are not covered under the warranty.



Warning

Before connecting:

1. Please check the product and packing list after unpacking. If the product is damaged or any part is missed, please contact your local dealer.
2. Before installation, please make sure to cut off mains supply and ensure that the battery is turned off.
3. Make sure that the wiring is correct, do not mistake positive and negative terminals of the cable, and ensure that no short circuit is caused to any external device.

4. Never connect the battery directly with the AC power supply.
5. Do not connect the battery in series as the embedded BMS in the battery is of 25.6 V DC design.
6. The battery must be grounded in a way that the resistance is less than 0.10 M Ω .
7. Please ensure that electrical parameters of the battery system are compatible with the relevant devices.
8. Please keep the battery away from water and fire sources.

Notice

During use:

1. If it is necessary to move or repair the battery system, be sure to cut off the power and completely turn off the battery.
2. Never connect the battery with other different types of batteries.
3. Never connect the battery with a faulty or incompatible inverter.
4. Never disassemble the battery.
5. Do not open, repair, or disassemble the battery, except for staff or authorized personnel. Vesol shall not be liable for any consequences or related liabilities arising from violations of safety operations or design, production, and safety standards of equipment.
6. Never connect the product with other models in parallel.

3. Product Introduction

HZ-LCT, the latest 25.6 V low-voltage DC energy storage system product (hereinafter referred to as "the product") developed by Vesol, can provide reliable power support for residential buildings and is a good partner for environmentally friendly living. This product shall be used in conjunction with a low-voltage inverter, and is incompatible with mainstream brand inverters available on the market. For this series of products, up to 15 batteries can be used in parallel.

3.1 Product characteristics

This system has following functional characteristics:



1. High voltage accuracy (≤ 20 mV)
2. High current accuracy ($\leq 2\%$ @FS)
3. Short-circuit protection
4. Adjustable overcurrent protection
5. Adjustable parameter settings

6. LED indication of product status
7. Charging equilibrium
8. Flexible configuration (multiple batteries can be connected in parallel to expand capacity)
9. Self-cooling mode (both noise and power consumption of the system itself are reduced significantly)

3.2 Product identification

Energy Storage Battery Pack	
Model:HZEB-LCT-2.5	Cell Type:LiFePo4
Rated voltage:DC25.6V	Voltage range:22.8V-28.8V
Energy:2.56kW·h	Capacity:100Ah
Recharging current:<100A	Discharge current:<100A
Working humidity:0~90% (non-condensing)	
Working temperature:-10℃~+55℃	
Protection Level:IP20	
Date of manufacture:2024.8.8	
Manufacturer:Jiangxi Hertz New Energy Technology Co.,Ltd	
UN38.3	
Made in China	

Interpretation of labels

-  Do not place near open flames or in the fire
-  Do not place in a damp environment
-  Do not dispose of discarded batteries in the trash can and have them recycled by professionals or organizations

3.3 Specifications and parameters

Model	HZEB-LCT-2.5
Cell type	LiFePO4
Rated power	2560Wh
Rated capacity	100Ah
Rated voltage	25.6V
Working voltage	22.4~28.8V
Charge-discharge rate	0.5C/1C
Standard charge-discharge current	50A
Maximum charge-discharge current	100A
Dimensions	520*350*150mm
Weight	32kg
Protection level	IP20
Charge temperature range	0~55°C
Discharge temperature range	-10~55°C
Cycle life	≥6,000 times 25±2°C, 100%DOD 0.5C, 70%SOH
Communication mode	CAN/RS485
Expandability	Up to 15 modules can be connected in parallel
Protection	Short circuit protection, overcharge protection, discharge protection, overcurrent protection, over temperature protection
Certification	MSDS/UN38.3
Compatible inverter	Growatt/Deye/Schneider/GoodWe/MEGAREVO, etc.

3.4 Appearance

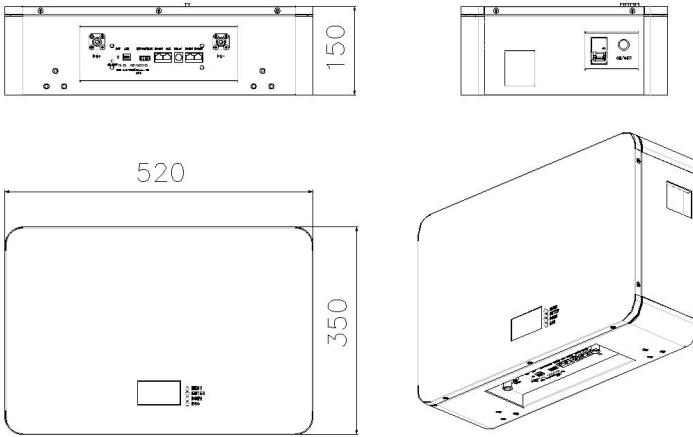

3.5 Appearance description

3.5.1 Definition of control panel

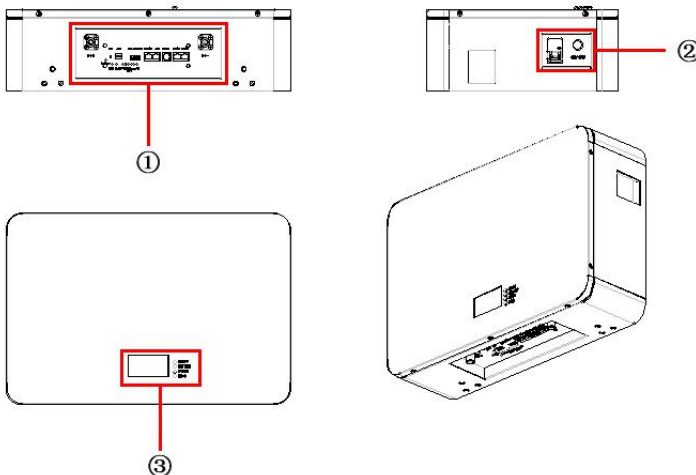

No.	Component
①	Signal communication panel and battery power interface
②	Battery switch

③ Key and display screen

3.5.2 Battery switch

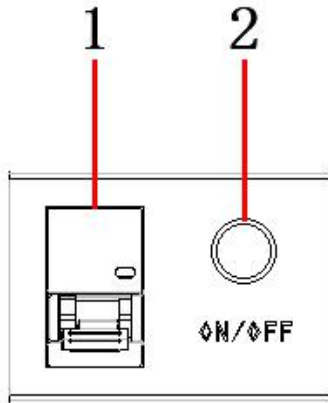

No.	Interpretation	Description
1	Circuit breaker	Power switch of battery power interface
2	ON/OFF	Protection board power switch

3.5.3 Signal communication panel

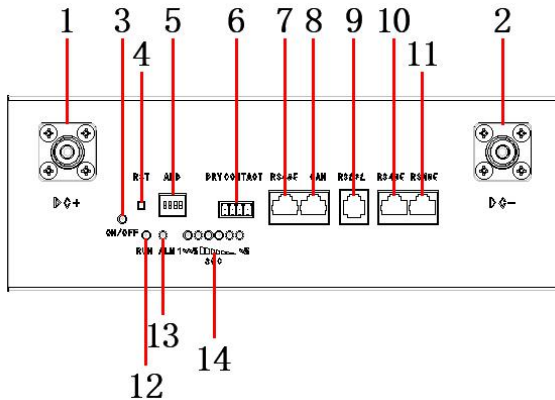

No.	Interpretation	Description
1	DC+	Battery output positive terminal
2	DC-	Battery output negative terminal

3	ON/OFF	Battery switch indicator
4	RST	Reset button
5	ADD	Dial switch
6	Dry Contact	Dry contact
7	RS485	Inverter RS485 communication port
8	CAN	Inverter CAN communication port
9	RS232	Upper computer communication port
10	RS485	Battery parallel operation port 1
11	RS485	Battery parallel operation port 2
12	RUN	Battery running indicator
13	ALM	Battery warning indicator
14	SOC	Battery power indicator

4. Storage and Packaging

4.1 Inspection before signing for acceptance

Before signing the product for acceptance, please check the followings carefully:

1. Check the outer packaging for any damage, such as deformation, holes, cracks or other signs that may cause damage to the device inside the packaging box. If there is any damage, please contact your dealer without opening the package.
2. Check whether the device model is correct. If there is any discrepancy, please contact your dealer without opening the package.
3. Check whether the type and quantity of the delivered parts are correct and whether there is any damage in appearance. If there is any damage, please contact your dealer.

4.2 Inspection of parts and components

Before installing the product, please check the following accessories carefully:

1. Battery
2. Wall-mounted bracket
3. Primary harness
4. Communication harness
5. Manual

4.3 Device storage

If the equipment will not be immediately put into operation, please store it according to the following requirements:

1. Make sure that the outer packaging box is not removed and that the desiccant inside the box is not lost.
2. It is recommended to complete installation of the device within 3 days after removing the packaging box. If the device is not installed, it shall be repackaged in the original packaging box for storage.
3. Keep away from flammable, explosive, and corrosive environments and items during storage.
4. Be sure to store it in a cool and shaded place, and avoid direct sunlight.
5. Recommended SOC range during storage: 30%–60%. A charge-discharge cycle shall be carried out every 3 months.
6. Storage temperature range:
 - When $-20^{\circ}\text{C} \leq$ the temperature $< 10^{\circ}\text{C}$, the storage time shall not exceed 1 month.
 - When $10^{\circ}\text{C} \leq$ the temperature $\leq 35^{\circ}\text{C}$, the storage time shall not exceed 1 year.
 - When $35^{\circ}\text{C} <$ the temperature $\leq 55^{\circ}\text{C}$, the storage time shall not exceed 1 month.
7. Storage humidity range: 0%–90% RH without condensation. If any moisture or condensation is found at the battery interface, the battery system shall not be installed.

5. System Installation

5.1 Installation requirements

Installation environment requirements:

1. The device shall not be installed in flammable, explosive, or corrosive environments.
2. The device shall be installed at a location that is far away from water pipes and cables inside the walls to avoid dangers during drilling.
3. The installation environment shall avoid direct sunlight, rain, snow accumulation, etc. It is recommended to install in a sheltered location. If necessary, a sunshade can be built.
4. The installation space must meet the ventilation and heat dissipation requirements of the device and the operation space requirements.
5. The device shall have a protection level that meets the requirements for indoor installation, and the temperature and humidity of the installation environment shall be kept within their respective appropriate ranges.
6. The installation height of the device shall facilitate operation and maintenance, ensuring that the device's indicators and labels are easily visible and that the terminal connectors are easily accessible.
7. The device shall be installed at an altitude below 2,000 m (the highest working altitude).
8. The device shall be kept away from strong magnetic field environments to avoid electromagnetic interference. If the installation location is close to a radio station or wireless communication device below 30 MHz, make sure that the battery is kept 30 m away from the device that generates wireless electromagnetic interference.

5.2 Installation of wall-mounted bracket



Note: Wall mounting shall be carried out by two people

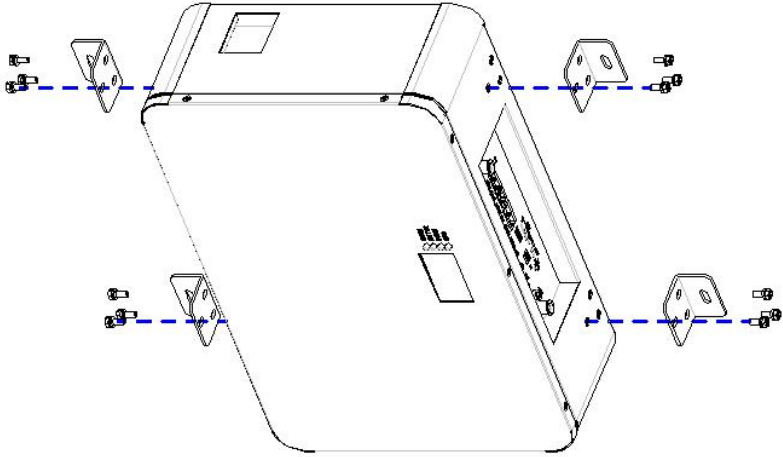

Step 1: Install the mounting ears onto the battery as shown in the diagram, with a torque of 10 N.m.

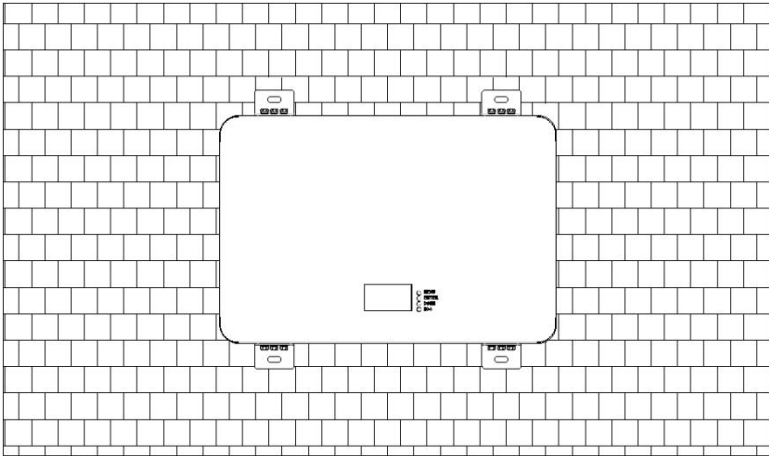

Step 2: Hold the wall-mounted battery against the wall to ensure that it is placed securely, use a marker to mark the location of the hole punched, and set aside the battery.

Step 3: Use an impact drill to drill holes on the wall (the spacing and depth of the holes depend on the expansion bolts).

Step 4: Hold the wall-mounted battery tightly against the wall to ensure that it

is placed securely, and then align with the hole drilled in step 3 to pre-tighten the expansion bolts.

Step 5: Tighten the expansion bolts with a torque of 10 N.m.

5.3 Wiring of single-battery system

5.3.1 Overview map of single-battery system wiring

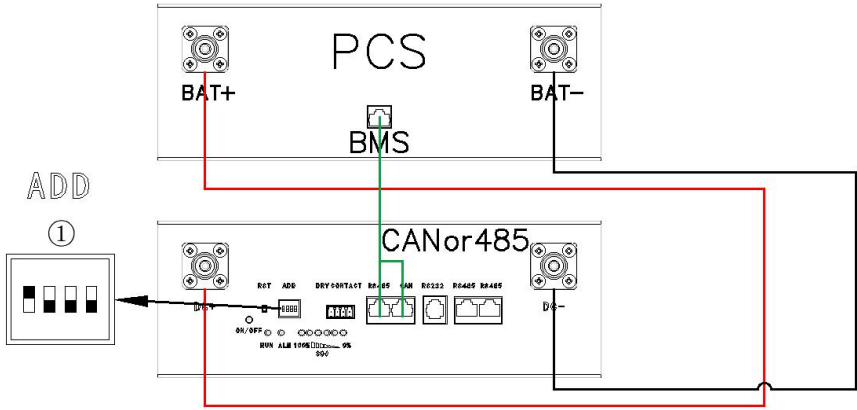

5.3.2 Power line connection

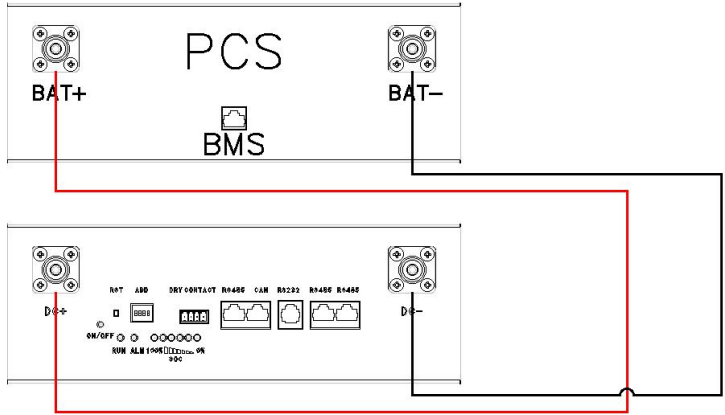

Step 1 Connect the battery DC+ to the inverter DC+/BAT+

Step 2 Connect the battery DC- to the inverter DC-/BAT-

5.3.3 Communication line connection

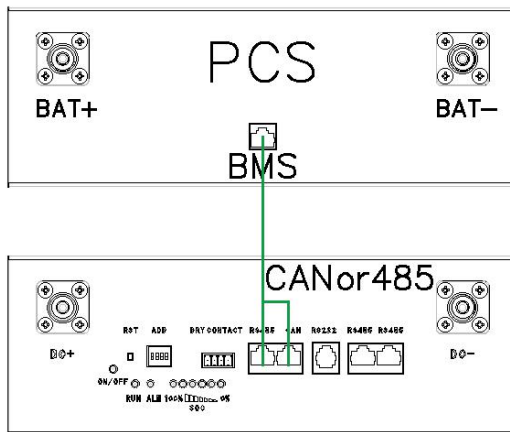

Step 1 Insert one end of the RJ45 communication line into the communication interface (CAN or RS485) of the battery host inverter

Step 2 Insert the other end of the RJ45 communication line into the communication interface (BMS, CAN, or RS485) of the inverter battery

Definition of communication interfaces:

RJ45 Registered Jack

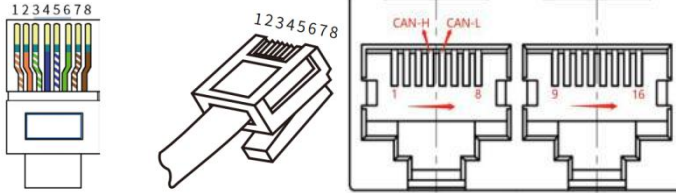

CAN -- 8P8C vertical RJ45 socket		RS485 -- 8P8C vertical RJ45 socket	
RJ45 pin	Description of definition	RJ45 pin	Description of definition
1, 3, 6, 7, 8	NC	9, 16	RS485-B1
4	CAN-H	10, 15	RS485-A1
5	CAN-L	11, 14	GND
2	GND	12, 13	NC

5.3.4 Address dialing

When a single battery is used, the battery address (ADD) shall be set to 1 by DIP switch, as shown in the following figure.

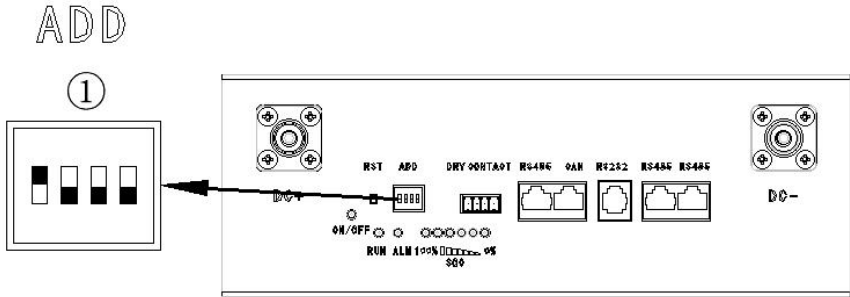

5.4 Wiring of multi-battery system

i Notice: When multiple batteries are connected in parallel, the host (i.e. No.1 battery) shall be connected to the inverter for communication

5.4.1 Overview map of multi-battery system wiring

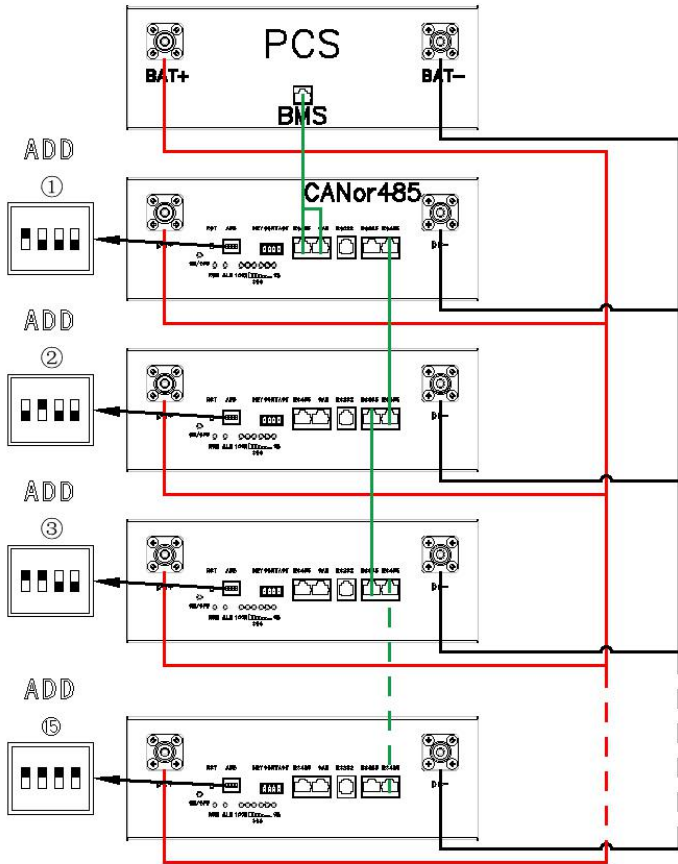

5.4.2 Power line connection

See 5.3.2

5.4.3 Communication line connection

See 5.3.3

5.4.4 Address dialing

When multiple batteries are connected in parallel for use, address (ADD) of each battery shall be kept different and sorted correctly to ensure normal operation of the system. For setting and definition of the DIP switch, please refer to the following table.

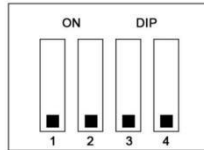

ADD	DIP switch position			
	#1	#2	#3	#4
1	ON	OFF	OFF	OFF
2	OFF	ON	OFF	OFF
3	ON	ON	OFF	OFF
4	OFF	OFF	ON	OFF
5	ON	OFF	ON	OFF
6	OFF	ON	ON	OFF
7	ON	ON	ON	OFF
8	OFF	OFF	OFF	ON
9	ON	OFF	OFF	ON
10	OFF	ON	OFF	ON
11	ON	ON	OFF	ON
12	OFF	OFF	ON	ON
13	ON	OFF	ON	ON
14	OFF	ON	ON	ON
15	ON	ON	ON	ON

6. System operation

6.1 Inspection before powering on

When the battery system is powered on, be sure to check the followings to prevent any damage to the system.

1. The inverter shall be installed firmly at a position that is easy to operate and maintain, a space that is conducive for ventilation and heat dissipation, and a clean and tidy environment.
2. The power lines and communication lines shall be connected correctly and firmly.
3. The cables shall be tied in a way that the routing requirements are met, distribution is reasonable, and no damage will be caused.

6.2 Battery power-on



Notice: The circuit breakers between inverter and battery and between batteries shall be installed according to local laws and regulations.

Step 1 Close the battery circuit breaker. (Optional)

Step 2 Press the battery button switch.

Step 3 Close the circuit breaker between the battery and the inverter. (Optional)

Step 4 Power on the inverters used in the system. For detailed operation, please refer to the user's manual of the inverter of corresponding model.

Step 5 Close the air switch of the load.

6.3 System operating topology

Single battery system:

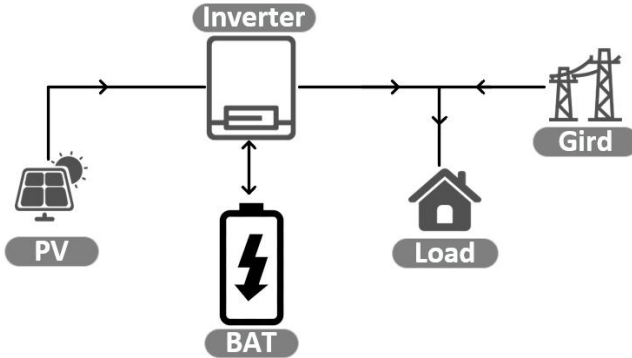

Multi-battery system:

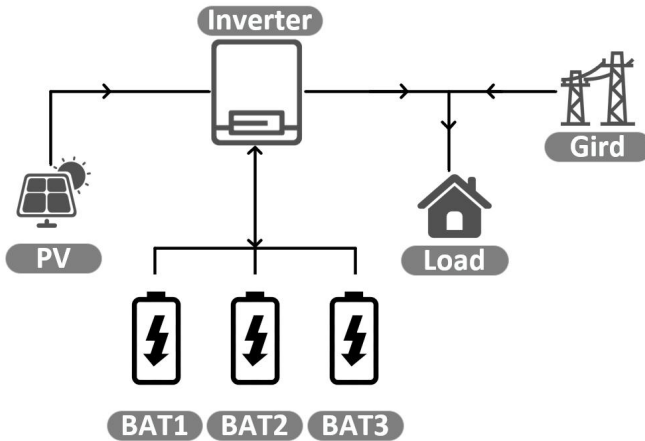

6.4 Battery protocol selection

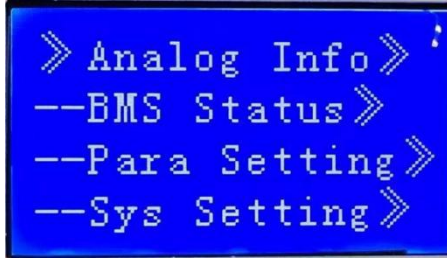

Click to enter Para Setting



Click to enter Set CAN Prot or Set 485 Prot

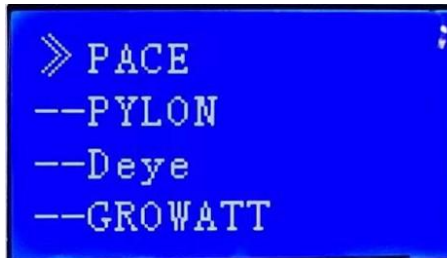

Select any protocol from the directory

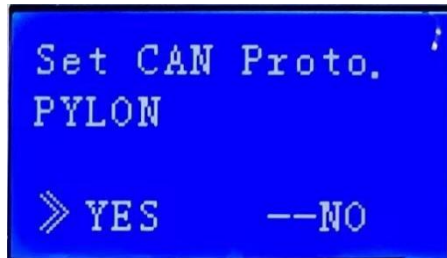

Click "YES"

6.5 Indicator lamp status



Description of indicators

Status	Normal / Alarm / Protection	ON / OFF	RUN	ALM	Power Indicator LED						Description	
		●	●	●	●	●	●	●	●	●		
Power-off	Sleep	OFF	OFF	OFF	OFF	OFF	OFF	OFF	OFF	OFF	OFF	All OFF
Standby	Normal	Always ON	Flash once	OFF	Depend on battery power						Standby status	
	Alarm	Always ON	Flash once	Flash three times							Voltage of module(s) is low	
Charging	Normal	Always ON	Always ON	OFF	Depend on battery power (The highest power indicator LED flashes twice)						The LED indicating the highest power level flashes (twice)	
	Alarm	Always ON	Always ON	Flash three times							ALM does not flash when an overcharge alarm is given	
	Overcharge protection	Always ON	Always ON	OFF	Always ON	Always ON	Always ON	Always ON	Always ON	Always ON	Always ON	If no mains power is available, the indicator

											switches to standby status
	Temperature protection, overcurrent protection, and fail-safe	Always ON	OFF	Always ON	OFF	OFF	OFF	OFF	OFF	OFF	Charging will be stopped
Discharging	Normal	Always ON	Flash three times	OFF	Depend on battery power						
	Alarm	Always ON	Flash three times	Flash three times							
	Under-voltage protection	Always ON	OFF	OFF	OFF	OFF	OFF	OFF	OFF	OFF	Discharging will be stopped
	Temperature protection, overcurrent protection, short-circuit protection, reverse connection protection, fail-safe	Always ON	OFF	Always ON	OFF	OFF	OFF	OFF	OFF	OFF	Discharging will be stopped
Failure		OFF	OFF	Always ON	OFF	OFF	OFF	OFF	OFF	OFF	Charging and discharging will be stopped

Description of power indicator

Status		Charging						Discharging					
Capacity indicator		L6	L5	L4	L3	L2	L1	L6	L5	L4	L3	L2	L1
		●	●	●	●	●	●	●	●	●	●	●	●
SOC (%)	0~16.6%	OFF	OFF	OFF	OFF	OFF	Flash twice	OFF	OFF	OFF	OFF	OFF	Always ON
	16.6~33.2%	OFF	OFF	OFF	OFF	Flash twice	Always ON	OFF	OFF	OFF	OFF	Always ON	Always ON
	33.2~49.8%	OFF	OFF	OFF	Flash twice	Always ON	Always ON	OFF	OFF	OFF	Always ON	Always ON	Always ON
	49.8~66.4%	OFF	OFF	Flash twice	Always ON	Always ON	Always ON	OFF	OFF	Always ON	Always ON	Always ON	Always ON
	66.4~83.0%	OFF	Flash twice	Always ON	Always ON	Always ON	Always ON	OFF	Always ON	Always ON	Always ON	Always ON	Always ON
	83.0~100%	Flash twice	Always ON	Always ON	Always ON	Always ON	Always ON	Always ON	Always ON	Always ON	Always ON	Always ON	Always ON
Running indicator ●		Always ON						Flash (three times)					

6.6 Battery power-off

To power off the battery system, please follow the following steps:

Step 1 Press the button switch

Step 2 Make sure that the indicator is off

Step 3 Disconnect the distribution circuit breaker

7. Maintenance

Maintenance Item	Maintenance Interval
If the battery is not put into use, it shall be fully charged and then discharged to 30%–60%.	Once every 3 months
Check whether the wall mount bracket is installed loose. If so, please tighten the corresponding position.	Once every 6 months
Check whether the case is damaged. If so, please repair the paint or contact for after-sales service.	Once every 6 months
Check the exposed cables for wear. If wear is found, replace the corresponding cable or contact for after-sales service.	Once every 6 months
Check whether any debris piled up around the battery. If any, please clean it to avoid heat dissipation of the battery from being affected.	Once every 6 months
Check whether any water or pests enter into the battery to avoid the battery from being invaded for a long period of time.	Once every 6 months



Warning:

- If any problems are found to have an impact on the battery or the battery and energy storage inverter system, please contact our after-sales personnel, and do not disassemble it without authorization; any damage caused by unauthorized disassembly shall be borne by the disassembling party.
- If the copper conductor inside any conductive wire is found to be exposed, do not touch it as the high voltage is dangerous, please contact our after-sales personnel, and do not disassemble it without authorization.
- In case of other emergencies, please contact our after-sales personnel at the first time, and operate by professionals under the guidance of our after-sales personnel.

Service E-mail: info@vesolenergy.com

Add.: Building 15, Economic Industrial Park, Yuanzhou
Economic and Technological Development Zone, Yuanzhou
District, Yichun City, Jiangxi Province, China

Postcode: 336000

※ The product information and parameters are subject to change
without prior notice.